



# SMAC 40D-24HP

(Service Maintenance Air Compressor)

## Owner / Operator Manual



**40 CFM Diesel Driven Air Compressor**

Document No 7208-D0001-01

Mobile Energy Australia Pty Ltd  
P: +61 7 3273 6803

39 Dulacca Street Acacia Ridge QLD 4110 Australia  
E: [sales@mobileenergyaustralia.com.au](mailto:sales@mobileenergyaustralia.com.au)

ABN 40 218 849 719  
[www.mobileenergyaustralia.com.au](http://www.mobileenergyaustralia.com.au)

**MEA Product Warranty Registration Form**

**THIS FORM MUST BE COMPLETED AND  
RETURNED WITHIN 30 DAYS OF INSTALLATION  
OR  
WARRANTY WILL BE VOID**

CUT HERE



## MEA Product Warranty Registration Form

**This form must be completed and returned to MEA at the time of Installation. Warranty will be void if this form is not received by MEA within 30 days of installation.**

### MEA Dealer Information

Company Name: \_\_\_\_\_

City: \_\_\_\_\_ State: \_\_\_\_\_ Country : \_\_\_\_\_

### MEA Installer Information

Company Name: \_\_\_\_\_

City: \_\_\_\_\_ State: \_\_\_\_\_ Country : \_\_\_\_\_

Installation Date:    \_\_\_\_ / \_\_\_\_ / \_\_\_\_  
                                  Day     Month     Year

### Owner Information

Company Name: \_\_\_\_\_

Address: \_\_\_\_\_

City: \_\_\_\_\_ State: \_\_\_\_\_ Country : \_\_\_\_\_

Postcode: \_\_\_\_\_ Phone #: \_\_\_\_\_

### Product Information

MEA Serial Number: \_\_\_\_\_

Model Number: \_\_\_\_\_

Document No 7208-D0001-01

Mobile Energy Australia Pty Ltd  
P: +61 7 3273 6803

39 Dulacca Street Acacia Ridge QLD 4110 Australia  
E: sales@mobileenergyaustralia.com.au

ABN 40 218 849 719  
www.mobileenergyaustralia.com.au

## Table of Contents

<b>COMPRESSOR / COMPRESSED AIR SAFETY .....</b>	<b>6</b>
<b>INTRODUCTION .....</b>	<b>7</b>
<b>COMPRESSOR SPECIFICATION .....</b>	<b>8</b>
<b>DIESEL ENGINE SPECIFICATION.....</b>	<b>9</b>
<b>INSTALLING THE COMPRESSOR UNIT .....</b>	<b>12</b>
<b>INSTALLING THE COMPRESSOR UNIT .....</b>	<b>13</b>
<b>SCHEDULE MAINTENANCE.....</b>	<b>19</b>
<b>SPARE PARTS AND SERVICE KITS.....</b>	<b>20</b>
<b>DRAWINGS &amp; ILLUSTRATIONS.....</b>	<b>23</b>
<b>HYDRAULIC PUMP INSTALLATION.....</b>	<b>30</b>
<b>WARRANTY .....</b>	<b>31</b>
<b>MOBILE ENERGY AUSTRALIA – CONTACTS.....</b>	<b>33</b>

Both the MEA Product Warranty Registration form (located at the front of this Manual) and the Kubota Engine Warranty Registration form (located at the back of this manual) are to be returned to MEA.

**FAILURE TO RETURN EITHER FORM MAY RESULT IN THE PRODUCT WARRANTY BEING VOID.**

## **COMPRESSOR / COMPRESSED AIR SAFETY**

---

**ME A DISCLAIMS ANY AND ALL LIABILITIES FOR DAMAGE OR LOSS DUE TO PERSONAL INJURIES, INCLUDING DEATH, AND/OR PROPERTY DAMAGE INCLUDING CONSEQUENTIAL DAMAGES ARISING OUT OF ANY ME A COMPRESSOR SYSTEM NOT USED IN ACCORDANCE WITH THE OPERATOR INSTRUCTIONS.**

**ALL UNITS ARE SHIPPED WITH A DETAILED OPERATOR MANUAL. THIS MANUAL CONTAINS VITAL INFORMATION FOR THE SAFE USE AND EFFICIENT OPERATION OF THIS UNIT. CAREFULLY READ THE OPERATORS MANUAL BEFORE STARTING THE UNIT. FAILURE TO ADHERE TO THE INSTRUCTIONS COULD RESULT IN SERIOUS BODILY INJURY OR PROPERTY DAMAGE.**

Care is required when working with an air compressor or compressed air. Compressed air is one of the many ways energy can be stored. Releasing the stored energy in an uncontrolled manner can result in catastrophic consequences. Death and permanent disability are all possibilities that can occur. The following are suggested as minimum precautions to be used when operating the SMAC Air Compressor. It is important that each work site engages in a risk analysis of that site and produces procedures in order to minimise injury to their employees. Health and Safety Regulations today require that this is a compulsory process to be carried out on each site. These, with site specific designed safety precautions will help to reduce accidents, personal injury and loss of life. It is the responsibility of the employer to ensure that the work site is safe for the employees.

### **SAFETY WHEN OPERATING AN AIR COMPRESSOR**

- Do not bypass or disable the oil temperature sensor.
- Do not expose the tank or compressor to extreme heat.
- Do not perform any service or repairs until the system has been completely relieved of air pressure.
- Maintenance and repairs on the system should only be done by qualified personnel.
- Do not operate the compressor while driving.
- Do not tamper with the pressure relief valve.
- Run the system at idle speed and under no load conditions for 2 to 3 minutes before turning the system off to allow system cooling and lubrication to occur.
- Follow safe work practices, wear the appropriate safety equipment when operating air-powered equipment, particularly eye and hearing protection.
- Avoid contact with rotating components, ensure all safety guards are in place.
- Avoid all contact with pressurized air. If it penetrates your skin, it can enter your blood stream and cause death.
- To prevent compressor explosion or fire, make sure that the air entering the compressor is free of flammable vapors.
- Vaporized oil propelled by high pressure is an explosive mixture.
- Do not breathe the compressor air, vaporized oil is a respiratory hazard.
- Stay clear of all moving parts when the system is operating.
- Follow safety procedures for tyre service operations as set by the authority.

## INTRODUCTION

---

This MEA (SMACD) Service Maintenance Air Compressor utilises a diesel engine to power the compressor. Only those who have been trained and who have read and understood the operator and installation manual should operate and install the MEA (SMACD). This manual contains vital information on integrating the compressor system into the vehicle system and to ensure that it is installed and operated in a safe and efficient manner. The following is a view of the SMAC compressor unit.



Detailed Information on the compressor and the engine are supplied separate to this Owner / Operator Manual.

The specifications on the following pages are an overview of the engine and the compressor used on this SMAC.

## COMPRESSOR SPECIFICATION

---

<b>Compressor Type:</b>	Oil injected rotary screw compressor		
<b>Drive System:</b>	Diesel powered via direct mechanical coupling		
<b>Control:</b>	Pneumatic		
<b>Maximum Air Delivery</b>	40 CFM @ 150 psi		
<b>Pressure Regulation:</b>	Mechanical inlet control valve modulates flow in response to demand		
<b>Inlet Valve Regulation</b>	Pneumatic		
<b>Engine Control System:</b>	Pneumatic speed control, engine and compressor high temperature and pressure engine shutdown system		
<b>Safety Features</b>	<p>200 PSI relief valve in compressor sump</p> <p>Temperature safety sensor in the compressor</p> <p>Rapid blow-down valve to discharge system pressure on shutdown</p>		
<b>Lubrication:</b>	<p>All replacement compressor oils must be approved by MEA prior to use. Warranty will be nullified if oil has not been approved.</p> <p>MEA certified and approved synthetic compressor oil <b>Part Number 10019 – P0002</b></p> <p>Quantity of Compressor Oil Required – 4 Litres</p>		
<b>Filters</b>	<p>Paper-type replaceable air filters</p> <p>Spin-on type compressor oil filter element</p> <p>Coalescing filter element</p>		
<b>Hydraulic Option</b>	Maximum Oil Flow	15HP 20lpm	24lpm
	Maximum Flow	15HP 210 bar	38lpm



## DIESEL ENGINE SPECIFICATION

---

<b>Engine Model:</b>	Kubota D902						
<b>Engine Type:</b>	3 Cylinder, water cooled, Diesel Combustion Engine						
<b>Power (continuous):</b>	17.5 Kw (23.5 HP) @ 3600RPM						
<b>Electrical System:</b>	12 Volts DC						
<b>Maximum RPM</b>	3600 (max bare speed)						
<b>Direction of Rotation:</b>	Counter Clockwise (viewed from flywheel)						
<b>Engine Control System:</b>	Electric key start pneumatic speed control via air cylinder,						
<b>Engine Protection:</b>	Engine low oil pressure and high water temperature sensors.						
<b>Lubrication:</b>	<p>MEA approved oil to meet strict emission control regulations, min. class “CF” or better is required. If oil does not meet the minimum requirements, all warranty will be nullified.</p> <p><b>IMPORTANT:</b></p> <p>Engine oil should be MIL-L-2104F or have properties of API classification CF grades or higher. Change the type of engine oil according to the ambient temperature.</p> <table> <tr> <td>Above 25°C (77°F)</td> <td>SAE30 or SAE10W-30 or SAE15W-40.</td> </tr> <tr> <td>0°C to 25°C (32°F to 77°F)</td> <td>SAE20 or SAE10W-30 or SAE15W-40</td> </tr> <tr> <td>Below 0°C (32°F)</td> <td>SAE10 or SAE10W-30 or SAE15W-40</td> </tr> </table> <p>Engine Oil quantity 2.5L</p>	Above 25°C (77°F)	SAE30 or SAE10W-30 or SAE15W-40.	0°C to 25°C (32°F to 77°F)	SAE20 or SAE10W-30 or SAE15W-40	Below 0°C (32°F)	SAE10 or SAE10W-30 or SAE15W-40
Above 25°C (77°F)	SAE30 or SAE10W-30 or SAE15W-40.						
0°C to 25°C (32°F to 77°F)	SAE20 or SAE10W-30 or SAE15W-40						
Below 0°C (32°F)	SAE10 or SAE10W-30 or SAE15W-40						
<b>Filters:</b>	<p>Air Filter - Paper-type replaceable (Not Possible to Clean)</p> <p>Oil Filter - Spin on type (Not Possible to Clean)</p> <p>Engine fuel filter – In Line Element (Not Possible to Clean)</p>						

## OPERATING PROCEDURE – CHECKS REQUIRED PRIOR TO STARTING EACH DAY

1. Check the oil level in the engine.
2. Check the water level in the engine.
3. Check the oil level in the compressor.
4. Check all hoses are secured and not damaged. Replace all damaged hoses before starting.
5. Check all electrical cables are secure. Secure all cables that are not tied down.
6. Check the air inlet and air filter on the engine are clear.

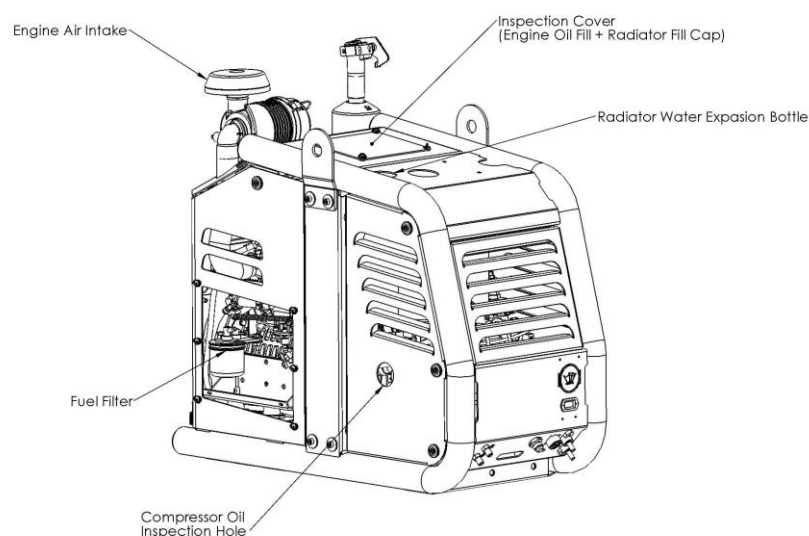
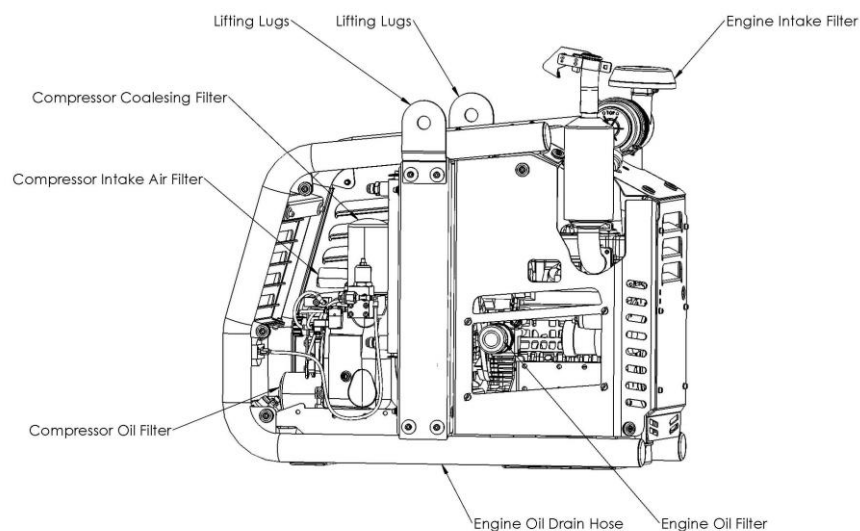

## **OPERATING PROCEDURE – STARTING / STOPPING DIESEL ENGINE AND COMPRESSOR**

---

### **STARTING THE DIESEL ENGINE**

1. Check the COMPRESSOR SWITCH is set to the OFF position.
2. Turn the key to the left for approximately 15 seconds to prime the fuel pump and to apply power to the glow plugs. Do not hold the key in this position for longer than 15 seconds. The system could be damaged should you extend the time beyond the 15 seconds.
3. Turn the key to the right until the engine has started and then release the key.
4. Allow the engine to run at no load for 2-3 minutes. This will allow the engine to warm up and lubrication system to be fully operational before the load is applied.
5. If the engine does not start, repeat the process described in 2 and 3 above. The maximum number of attempts should be limited to perhaps 4 and after this; the operator should seek assistance from a mechanic.

### **STARTING THE COMPRESSOR**

1. Set the COMPRESSOR SWITCH to the ON position. This will engage the compressor load solenoid and a green light will glow on the remote control box. The engine speed will increase until the preset regulated pressure is reached.
2. Listen for air escaping from the pressurized air system. Ensure all air line taps are closed in order to reach regulated pressure.
3. If the escaping air is from a broken pipe or connection, turn the COMPRESSOR SWITCH to the OFF position. Stop the diesel engine. Advise your maintenance department that you require their assistance.
4. The engine will reduce its RPM when the compressor reaches the preset regulated pressure. The compressor is now ready to be used. (It should be noted the preset regulated pressure can be adjusted via the regulator control valve. It is recommended that your maintenance department does this if required.)
5. The compressor is ready to use.

### **STOPPING THE COMPRESSOR UNIT**

1. Disengage the compressor by moving the compressor engage switch to the “Compressor Off” position. Green light will turn off.
2. The compressor will shut down and bleed off pressure. The engine will come down to idle speed.
3. It is good practice to allow the engine to run under no load for 2-3 minutes.
4. Turn the engine off by turning the ignition key to the off position. If you hear a slight “hissing” noise this is normal, the compressor is bleeding off excess pressure out of the system.

## INSTALLING THE COMPRESSOR UNIT

---

The compressor is a rotary screw type driven by a diesel engine. Compression occurs when inlet air (at normal atmospheric pressure) enters a chamber where it is trapped between the rotating rotor lobes. A lubricated pitch line provides sealing. As the lobes mesh, they reduce the volume of the air, compressing it to the desired pressure.

The system has a two-stage air/oil separator. The first separation stage consists of baffles, which perform mechanical separation. The second stage uses a special separation element, which delivers dry air to the outlet. The second stage is a spin-on type coalescing filter.

Pressure regulation is achieved by adjusting the pressure regulator valve mounted in front of the compressor (Gold adjustable valve). The system pressure is pre-set at 150 psi. To reduce the pressure, either adjust the regulating valve or use a Filter Regulator Lubricator (FRL) to achieve the final tool pressure.

The compressor air intake is protected by a paper-type replaceable air filter, and a spin-on type oil filter for the oil side and a coalescing filter for final oil removal from the air.

Safety features included in the compressor are:

- 200 PSI relief valve in separation manifold.
- Blow-down valve to discharge system pressure on shutdown.
- Over temperature safety sensor in the compressor oil.
- Over pressure mounted at the minimum pressure valve.

**Do not disable or bypass the over-temperature shutdown circuits. Failure of the shutdown system could result in equipment damage, injury or death.**

A liquid-to-liquid air cooler with thermo bypass valve maintains operating temperatures in an optimal performance range. This helps to increase system durability and reduces the temperature of the compressed air.

### Installation of Compressor Unit

The information in this section is very important for proper operation of the compressor. Read these requirements before beginning installation. The following is a view of the compressor/diesel engine unit.

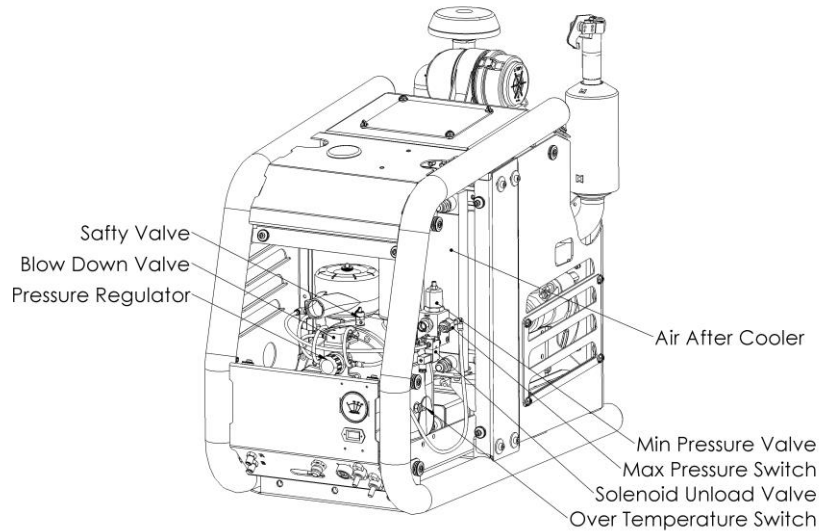

### INSTALLING THE COMPRESSOR UNIT

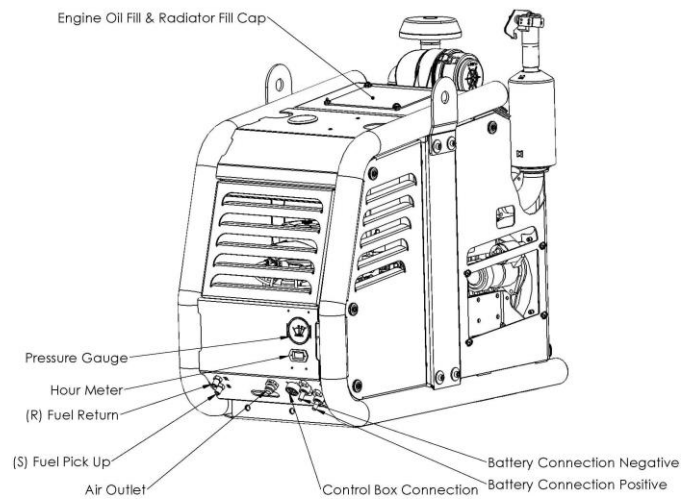

## 1. General Consideration When Mounting the Compressor Unit

The starting point for the installation is a quick overview of the requirements. Some of these points will be dealt with in more detail further on in this text. Things that should be considered now are as follows;

1. The unit should be installed in an open area.
2. The unit will need to be properly secured to the vehicle by means of bolts and nuts.
3. It should be possible that the sight level glass for oil level can be checked easily.
4. It should be possible to service the unit easily without having to disconnect lines or remove and reposition the unit.
5. The unit should be protected from excessive exposure to the elements and possible incidental damage from other operations.
6. The unit should be installed in an area away from heat sources such as engines, exhaust systems or other components that generate heat.
7. The unit should not be installed in a location where it will be exposed to high contamination levels or combustible gases.
8. The engine exhaust should be routed away from the compressor unit. The engine exhaust should be located in an area where the exhaust CANNOT be filled up with rain (an exhaust flapper is fitted to the exhaust).

## 2. Mounting of Compressor Unit Considering Ventilation

It is not possible to make absolute recommendations regarding ventilation because of the widely differing circumstances that are possible. Duty cycle, ambient temperature and enclosure shape are some of the important variables. Ideal ventilation will provide good airflow through the unit with no restrictions. Broadly speaking, there are two ways in which the SMACD compressor can be mounted.

### Top or Deck Mounting

This is the preferred mounting location. Placing the unit in an area where there are no restrictions on the intake of fresh air and exhausting of hot air and exhaust gases this provides the best cooling and ensures reliability and life for the compressor / diesel engine driven unit.

### Enclosed Mounting

It is important that discussion occurs between the manufacturer and the person installing the unit when it is to be placed in an enclosed area. Ventilation is one of the most important things to consider when looking at the installation of a compressor/diesel engine driven unit in an enclosed area. It is important that the air intake to the compressor and the engine exhaust are located outside of the enclosed space. The unit generates a considerable amount of heat when running. Proper ventilation is vital for proper operation and to avoid damage to components. Ensure there is a minimum of 10" (250 mm) clearance between cooler grills and SMACD and any other components mounted on the vehicle. It is strongly recommended that the installation is tested in the event that the unit is installed in an area considered to be enclosed mounting. The following is a method suggested for testing.

1. It is best to test the installation at the hottest expected ambient temperature.
2. Setup and run the system at 120 PSI. This can be done by installing a ball valve on the air outlet pipe and adjusting the opening of the valve so that the compressor is running continuously at 120 PSI.
3. Record the engine, compressor and current ambient temperature for future reference.
4. Run the system at full load for at least one hour or until the temperatures stabilizes. Temperature stabilizing means there is no rise in temperature for 15 minutes when the compressor is running at the rated load.
5. Record the engine and compressor temperatures every 10 minutes.
6. If the system over-temps, the ventilation is not sufficient, review the installation, make changes as needed, and repeat the test.

### **3. Engine Exhaust consideration when installing Diesel Engine Driven Compressor Unit**

In the event that the exhaust system needs to be ducted away from the engine assembly, the following are a minimum that should be considered.

- The exhaust pipe needs to be adequate for the engine.
- There needs to be a flexible joint at the point where the extension is connected to the exhaust system of the Diesel Engine Driven Compressor Unit.
- Ensure the exhaust pipe has suitable clearance and does not come in contact with anything.
- Ensure that if the exhaust system has a method to prevent water from entering the exhaust system.
- Ensure exhaust from the diesel engine is routed in a way to prevent recirculation back into the unit.

### **4 Securing the Diesel Engine Driven Compressor Unit to the body of the vehicle.**

It is important to consider maintenance needs, (in particular daily needs), service requirements, electrical connections, air connections and location of control panel before the SMAC is secured to the body of the vehicle.

- Locate a suitable mounting position for SMACD. Place the unit and check for clearances to any other objects.
- There are four weld nuts located at the four corners of the bottom formed plate which can be used as mounting bolt locations. Holes can also be drilled through the bottom of the formed plate if alternate locations are required.
- Drill four holes in mounting surface and secure the SMAC to the truck. Use a minimum of 4 – M12 bolts. .

## 5. Connecting Truck Electrics to the Diesel Engine Driven Compressor Unit

Electrical connection of the SMAC to the truck is very simple. The entire control system is mounted in the SMAC.

- The SMAC needs to be connected the truck battery. A minimum of 25mm cable is required for the connection because the SMAC is started using the truck battery. SMACD units are 12 Volt DC. In the event that a truck is 24 Volt DC (Two of 12 Volt DC batteries are supplied in the truck), connection for the SMAC Unit will be across 1 of the batteries.
- The start switch control box which includes the compressor load and unload switch needs to be connected to the SMAC front panel via the Deutsch plug provided at the end of the 5 metre cable of the control box. It should be noted, this switch box can be mounted in the cab of the vehicle if an extension harness is purchased or any location on the vehicle.

## 6. Connection of the Diesel Engine Driven Compressor Unit to the fuel tank

It is normal to use the trucks fuel tank for all models of the SMACD. The SMACD has as standard a fuel pump built into it. It is suggested that an additional electrical fuel pump is installed if the compressor unit is installed 20" (500 mm) above the height of the truck diesel tank. The following is the method for connecting up the fuel to the compressor unit.

1. Cut the feed and return lines at the tank. Install the tees into the cut pipes.
2. Install the provided check valve at the T-Piece of the feed pipe.
3. Connect the diesel feed pipe to the compressor unit from the check valve. Connect the return line from the compressor unit to the return line tee.

## 7. Remote Air Intake Filter Removed For Shipping (Optional)

A label on the unit will indicate if the Air Compressor Filter has been removed for the purpose of shipping. IT IS IMPORTANT THAT THE FILTER IS FITTED BEFORE THE COMPRESSOR IS STARTED. The following is the instruction for fitting the filter to the compressor.

1. Remove the front access panel by pulling out the top of the panel until it is free of the rubber mounts, lift to free from bottom rubber mounts.
2. Put the hose clamp over the air hose protruding through the top panel and push the Air Intake Filter inlet tube into the hose.
3. Using the 2 off M8 x 30 bolts, flat washers, spring washers and nuts, bolt the Air Intake Filter into place.
4. Tighten the hose clamp and refit the front panel.



## INSTALLING THE COMPRESSOR UNIT (continued)

### 8. Optional Supply of After Cooler for Diesel Engine Driven Compressor Unit

It is important for the majority of air tools that the air supplied should be free of moisture. High content of moisture in the air will considerably reduce the reliability and life of the air tool. In applications such as painting with air guns, the finish can be greatly affected by moisture in the air.

Filters used in the standard filter regulator lubricator units have a limit to what they can handle. It is suggested in areas of high humidity or in situations where the standard FRL is not able to cope with the moisture that a MEA AFTERCOOLER (Part Number 7201-B0020) is installed onto the compressor unit. The following picture shows the MEA AFTERCOOLER installed onto a SMACD.

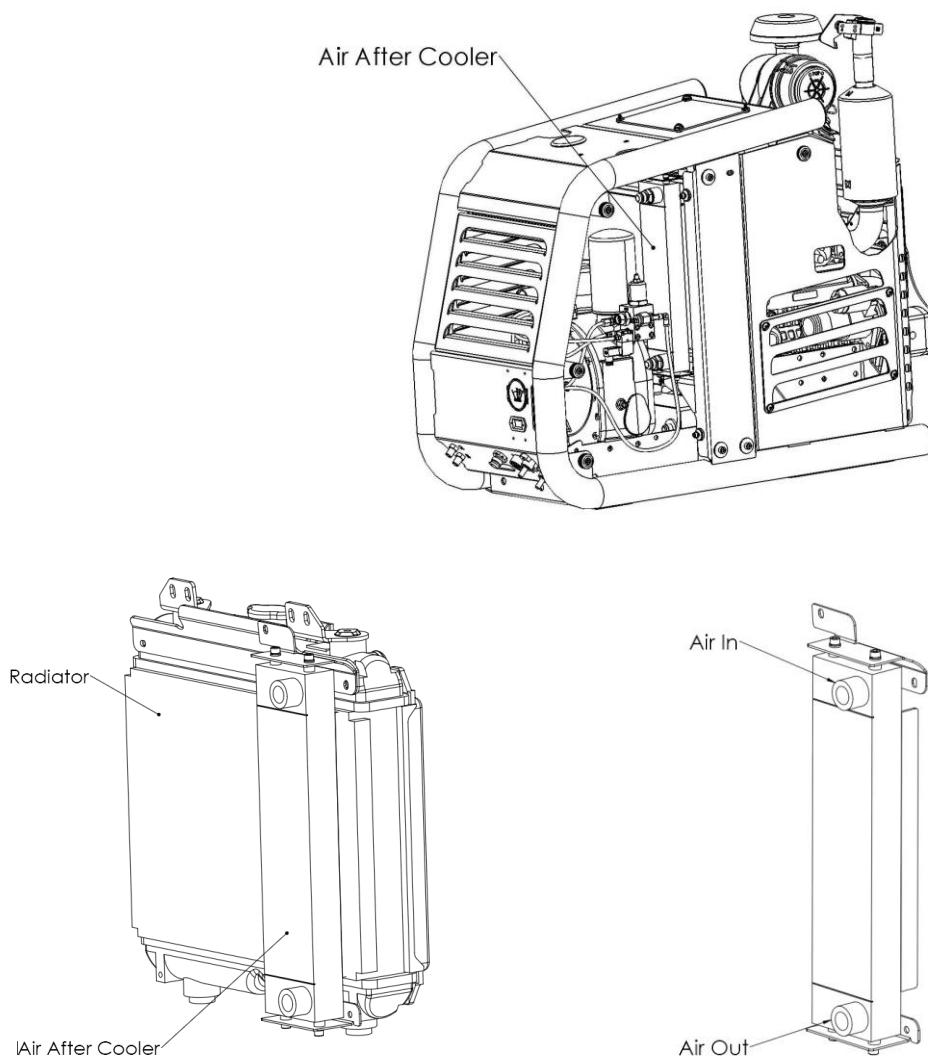

## **INSTALLING THE COMPRESSOR UNIT (continued)**

---

### **9. Completing the Installation - Before the Check**

Make sure that the following have been completed before operating the MEA Diesel Engine Driven Compressor Unit

1. Check the compressor oil level; make sure the compressor has been filled to the correct level prior to shipping. Note that the oil is very clear and it is difficult to see the level.
2. Check the engine coolant level.
3. Check the engine oil level.
4. Check fuel level.
5. Do a final inspection to make sure that all fasteners and connections are tight.
6. Check that all hoses and wiring are secure and protected.

### **9 Check Operation - Setup, Performance Testing and of Diesel Driven Compressor**

1. The compressor is dispatched from the factory with the pressure preset to the customer specification. Should the customer want to alter this setting, the instruction on how to do this can be found in the compressor manual.
2. Install the ball valve on the outlet of the hose from the compressor. Set the ball valve to the closed position.
3. Refer to Pages 7 and 8 of this manual for the method to be used to start the compressor.
4. On starting and running, the air pressure will be found to be at the pressure specified by the customer and the engine will be at the lower speed (idle speed). The Unit has been adjusted by the factory to the customer specification. If the pressure is not at the specified pressure, refer to MEA before attempting any adjustments.
5. Listen for leaks in the air line. You should hear a hissing sound if there are any leaks. Rectify any leaks you may find.
6. Keep the system running at the preset pressure until the compressor is up to operating temperature.
7. Using the ball valve located on the outlet of the compressor, slowly open the ball valve and watch the pressure drop. The pressure will drop up to the point that the pressure is 20 PSI below the setting detailed in 1 above. The engine will speed up to the maximum preset RPM.
8. Keep the opening of the ball valve at the setting described in (7) above for about 5 minutes. The engine should continue to run at the maximum preset RPM.
9. Slowly close the ball valve and watch the pressure while closing. The engine will drop to the lower speed when the pressure described in (1) above.
10. Your compressor is working correctly if it is operating as per this description.

## SCHEDULE MAINTENANCE

The maintenance intervals recommended are for standard operating conditions, the intervals for inspection, lubrication and maintenance are maximum intervals. More frequent inspections should be made if the unit is operating in a dusty environment, in high ambient temperatures or in other unusual conditions. A planned program of periodic inspection and maintenance will help to avoid premature failure and costly repairs. Daily visual inspections should become routine.

SMAC D SERVICING			
ROTORCOMP	HRS	KUBOTA ENGINE	SEE KUBOTA MANUAL
	50	50 HR SERVICE	REFER TO MANUAL
	200	100HR SERVICE	REFER TO MANUAL
400HR SERVICE	400	400HR SERVICE	REFER TO MANUAL
	600	100HR SERVICE	
800 HR SERVICE	800	400HR SERVICE	REFER TO MANUAL
	1000	100HR SERVICE	
400HR SERVICE	1200	400HR SERVICE	
	1400	100HR SERVICE	
800 HR SERVICE	1600	400HR SERVICE	REFER TO MANUAL
	1800	100HR SERVICE	
400HR SERVICE	2000	400HR SERVICE	
	2200	100HR SERVICE	
800 HR SERVICE	2400	400HR SERVICE	
	2600	100HR SERVICE	
400HR SERVICE	2800	400HR SERVICE	
	3000	100HR SERVICE	REFER TO MANUAL
800 HR SERVICE	3200	400HR SERVICE	
	2 YEARS		REFER TO MANUAL

## SCHEDULE MAINTENANCE (continued)

Interval	Compressor	Diesel Engine
Action to be taken		
Periodically During Operation	Observe all gauge readings. Note any change from the normal reading and determine the cause. Have the necessary repairs made. (Note: "Normal" is the usual gauge reading when operating at similar conditions on a day to day basis.)	
Every 10 Hours or Daily	Check the compressor oil level.	Check engine oil level
	Check air filter/s and connecting hose and clamps	
	Check for oil and air system, including hoses, for leaks	
		Check water level
Weekly Check		Check Cone locks on Exhaust Manifold are tight*
Every 25 Hours or Monthly	Drain water from Compressor and check oil level	
After first 50 hours of operation (7201-K0017)		Change engine oil filter cartridge
	Check system for oil and/or air leaks	Check all fuel hoses and clamping bands
	Check engine/compressor/generator mounts for excessive wear and fastener torque.	
Every 100 Hours	Check shaft couplings for movements on shafts	
	Check engine/compressor/generator mounts for excessive wear and fastener torque.	
	Check compressor oil level	Change engine oil (see system specifications, diesel engine, lubrication)
	Check system for oil and/or air leaks	
		Clean air cleaner element
	Check fan belt tension	
Every 200 Hours of Operation or 6 months		Check radiator hoses and clamping bands
		Change engine oil filter cartridge
		Change engine oil (see system specifications, diesel engine, lubrication)
Every 400 Hours of operation or 9 months Engine compressor see Service Kit List		Change engine air intake filter if necessary
	Change compressor oil 3L	Change Engine oil
	Change compressor oil filter	Change engine oil filter
	Change compressor air filter	Replace in-line fuel filter element
		Check engine fan belt
		Check drive coupling
		Check fuel filter if necessary
	Check engine mounts	
800 Hours / 18 months	Change compressor oil filter	Replace engine air filter and service as per 400 hrs service
	Change compressor coalescing filter	
	Change compressor air filter	
Periodically or as required	Inspect and replace spin-on coalescing element if necessary	Inspect and clean oil cooler fins
		Check fuel filter
	Check system for oil and/or air leaks	Check valve clearance
Every 1500 hours		Check Kubota Manual

\*If Cone locks are not fitted please notify MEA

Document No 7208-D0001-01

Mobile Energy Australia Pty Ltd  
P: +61 7 3273 6803

39 Dulacca Street Acacia Ridge QLD 4110 Australia  
E: sales@mobileenergyaustralia.com.au

ABN 40 218 849 719  
www.mobileenergyaustralia.com.au

## SPARE PARTS AND SERVICE KITS

(SEE SERVICING SCHEDULE PREVIOUS 2 PAGES)

### SERVICE KITS FOR CURRENT SPECIFICATION OF SMAC

Code	Description
7201-KB0017	SERVICE KIT SMAC D/G 50HR STANDARD – ENGINE ONLY
7201-KB0015	SERVICE KIT SMAC D/G 200HR STANDARD – ENGINE ONLY
7201-KB0013	SERVICE KIT SMAC D/G 400HR DONALDSON INTAKE, METAL FUEL BOWL
7201-KB0028	SERVICE KIT SMAC D/G 800HR DONALDSON METAL

### LEGACY SERVICE KITS SMAC MACHINES BUILT BEFORE 01/01/2016

Code	Description
7201-KB0017	SERVICE KIT SMAC D/G 50HR STANDARD – ENGINE ONLY
7201-KB0015	SERVICE KIT SMAC D/G 200HR STANDARD – ENGINE ONLY
7201-KB0011	SERVICE KIT SMAC D/G 400HR STANDARD
7201-KB0022	SERVICE KIT SMAC D/G 800HR STANDARD
7201-KB0013	SERVICE KIT SMAC D/G 400HR DONALDSON, METAL FUEL BOWL
7201-KB0028	SERVICE KIT SMAC D/G 800HR DONALDSON, METAL FUEL BOWL
7201-KB0018	SERVICE KIT SMAC D/G 400HR DONALDSON, PLASTIC FUEL BOWL
7201-KB0029	SERVICE KIT SMAC D/G 800HR DONALDSON, PLASTIC FUEL BOWL
7201-KB0014	SERVICE KIT SMAC D/G 400HR MANN HUMMEL, METAL FUEL BOWL
7201-KB0030	SERVICE KIT SMAC D/G 800HR MANN HUMMEL , METAL FUEL BOWL
7201-KB0019	SERVICE KIT SMAC D/G 400HR MANN HUMMEL , PLASTIC FUEL BOWL
7201-KB0031	SERVICE KIT SMAC D/G 800HR MANN HUMMEL , PLASTIC FUEL BOWL

### SPARE PARTS FOR ALL SMAC MACHINES

Code	Description
4000-P0004	Compressor Shaft Seal
4000-P0001	Thermo Bypass Valve
7201-KB0001	Regulator/Blow Down Exchange Assembly Kit
4000-P0009	Regulator Seal Kit
20001-P0001	Temperature Sensor
10012-P0001	Safety Valve
20001-P0002	Over Pressure Switch
7201-P0088	Compressor Drive Coupling
N/A	Temperature Sensor
10001-P0043	Alternator
10001-P0033	Starter Motor
10005-P0001	Air Throttle Spring
10016-P0001	Throttle Cylinder
10016-P0008	Dual Speed Cylinder
10025-P0001	Exhaust Flapper
20010-P0001	Engine Idle Up Controller

**IMPORTANT: PLEASE CONTACT MOBILE ENERGY AUSTRALIA FOR MORE INFORMATION IF YOU HAVE ANY QUESTIONS REGARDING THE SETUP AND OPERATION OF THE SMAC RANGE OF PRODUCTS.**

Document No 7208-D0001-01

Mobile Energy Australia Pty Ltd  
P: +61 7 3273 6803

39 Dulacca Street Acacia Ridge QLD 4110 Australia  
E: sales@mobileenergyaustralia.com.au

ABN 40 218 849 719  
www.mobileenergyaustralia.com.au

SMAC DIAGNOSTIC CHART

SMAC 40D		
Symptom	Cause	Remedy
Engine not starting	Fuel pump working	Bleed fuel lines at filter, injectors
	Does system have fuel/ dirty fuel	IS Check valve fitted in fuel lines
	Fuel getting to injectors? 12VDC supplied to unit	Is fuel lift greater than 500mm, fit lift pump as close to fuel supply
	Starter motor not working	Replace Starter motor, check fuel supply
Will not make Pressure	Does MAC valve have power	Check fuses
	Adjust pressure regulator	Check for debris internal of pressure reg
	Does air bypass pressure regulator	Check blowdown shuttle valve/MAC/control lines
System shuts down unexpectedly	What pressure does system fail at	Check over pressure switch
	Is it over temp of compressor	Check oil level of compressor
	Does Stop solenoid activate	Check over temp of engine
	Starving of fuel in filter	Check oil pressure of engine
	Shut down timer relay failure	Bleed fuel lines/Lift pump/Check valve Check power circuit
Engine does not shut down when key turned off.	Does Stop solenoid activate	Check 15A fuse in loom
	Loose connection in loom	Check duetsch plug for loose wire
		Check loom connections
High moisture out of air outlet	High humidity area	Fit after cooler for air line
	Check water separator internals	Check float inside filter bowl
Water in compressor oil	Drain / Syphone water from oil	Run unit for longer periods to get to working temps
Engine not going to high speed	Is spring fitted to throttle cylinder	Replace spring
	Check cylinder for movement	
	Does air bypass pressure regulator	Check blowdown shuttle valve/MAC/control lines
Harness burnt	Earth connection from SMAC to Earth connection point on vehicle	Make good earth connection
	Check voltage supply	Make correct connection
Hour meter not working	Replace meter and record last know reading	
Oil found in air outlet	Has separator been damaged / due for service	Replace separator / coalescer
	Check sealing copper ring at base of separator	
unit over heating	check unit ventilation	Reposition unit
		Fit ventilation fans

**DRAWINGS & ILLUSTRATIONS**

Electrical Schematic - Standard Version

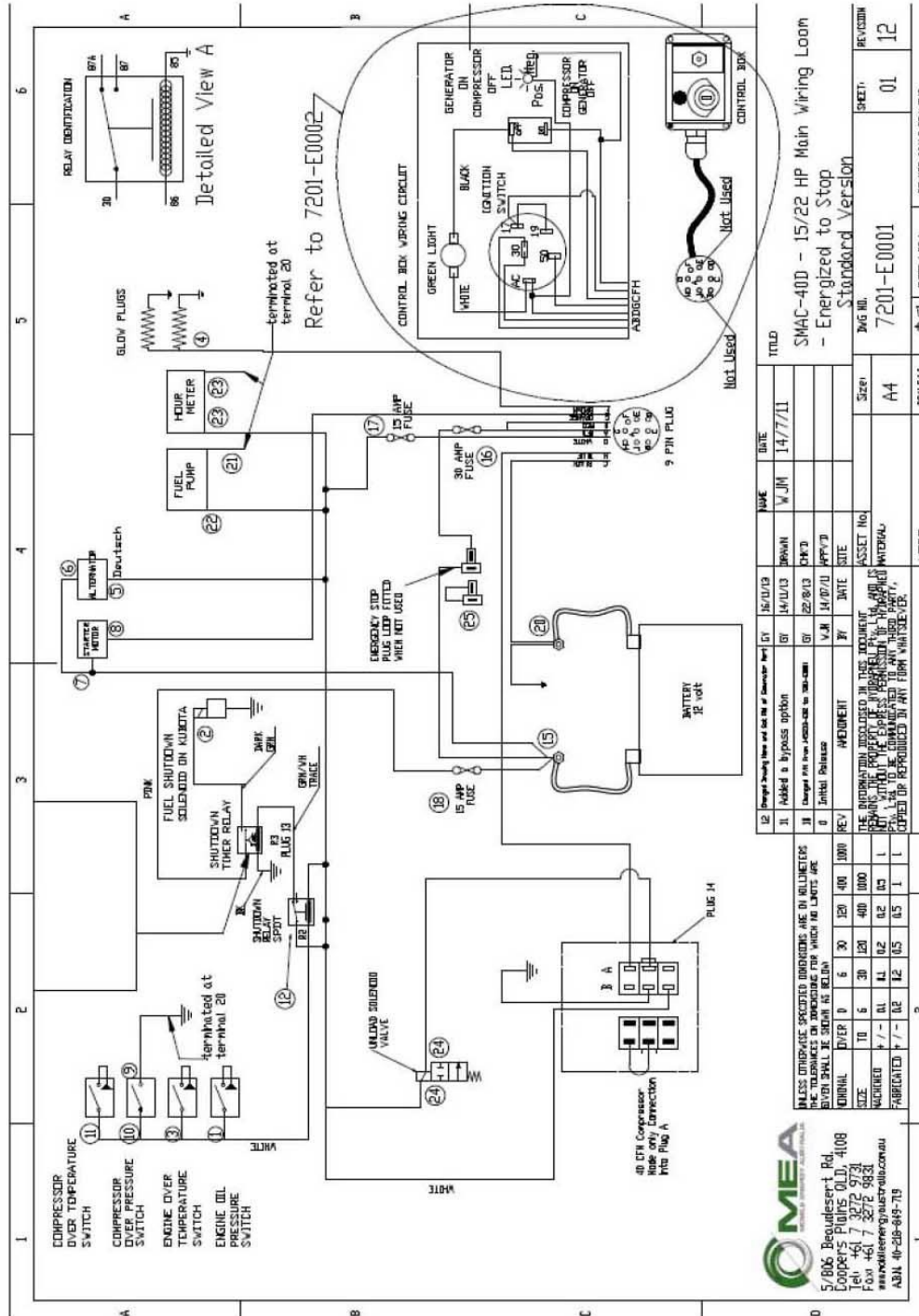

**DRAWINGS & ILLUSTRATIONS**

Electrical Schematic - Hydraulic Option

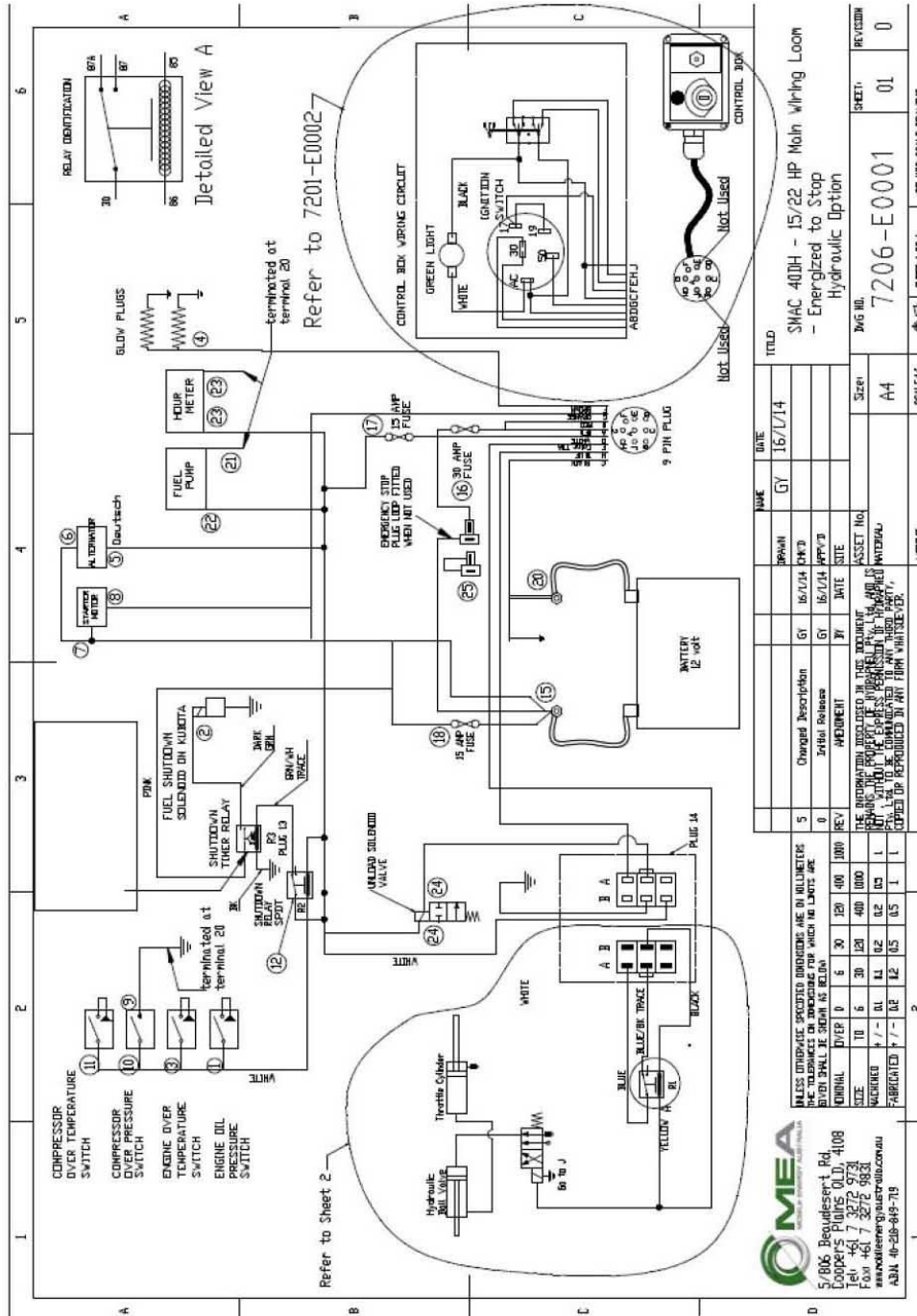



## DRAWINGS & ILLUSTRATIONS

Pneumatic Control Circuit

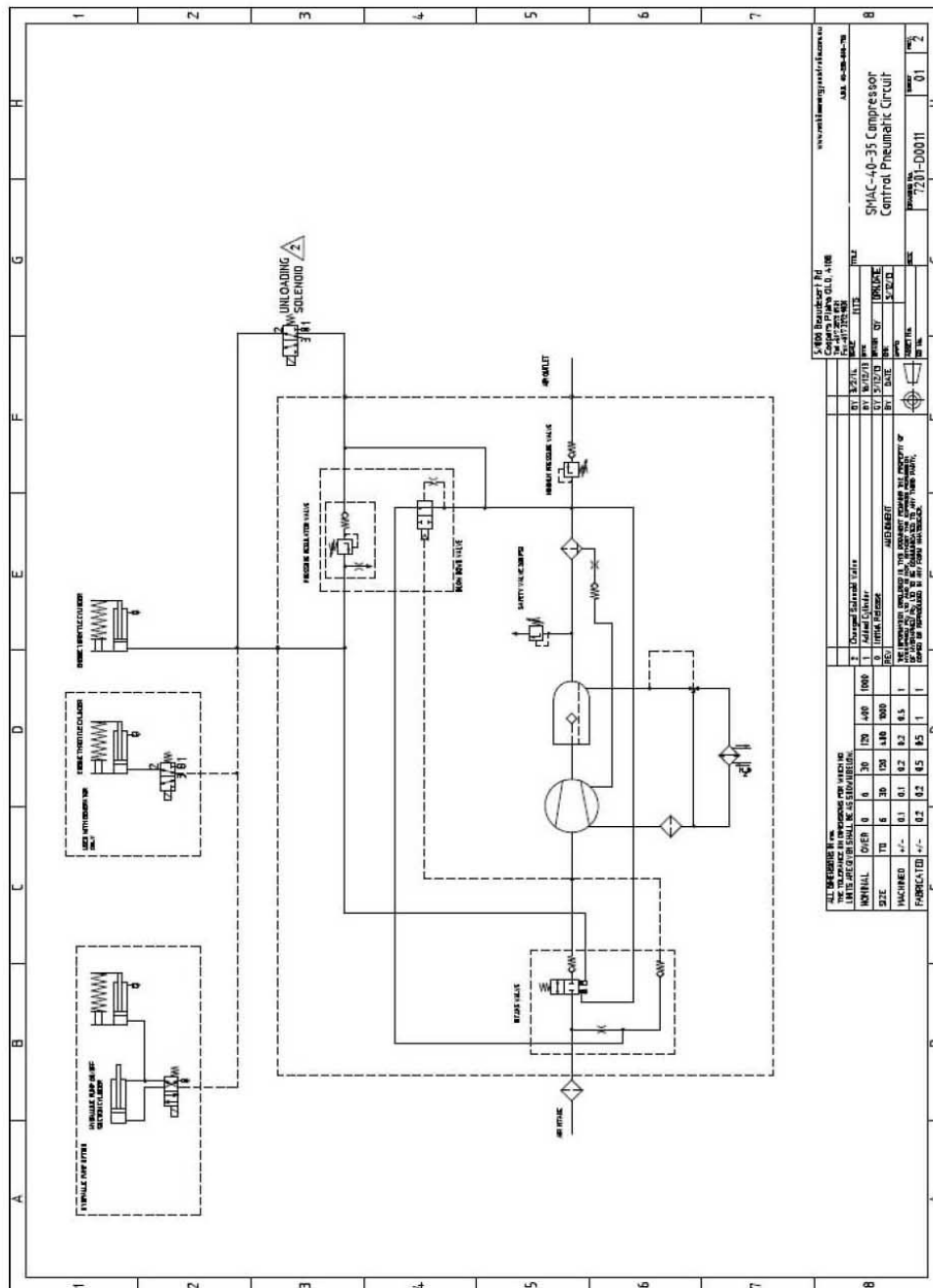

## DRAWINGS & ILLUSTRATIONS

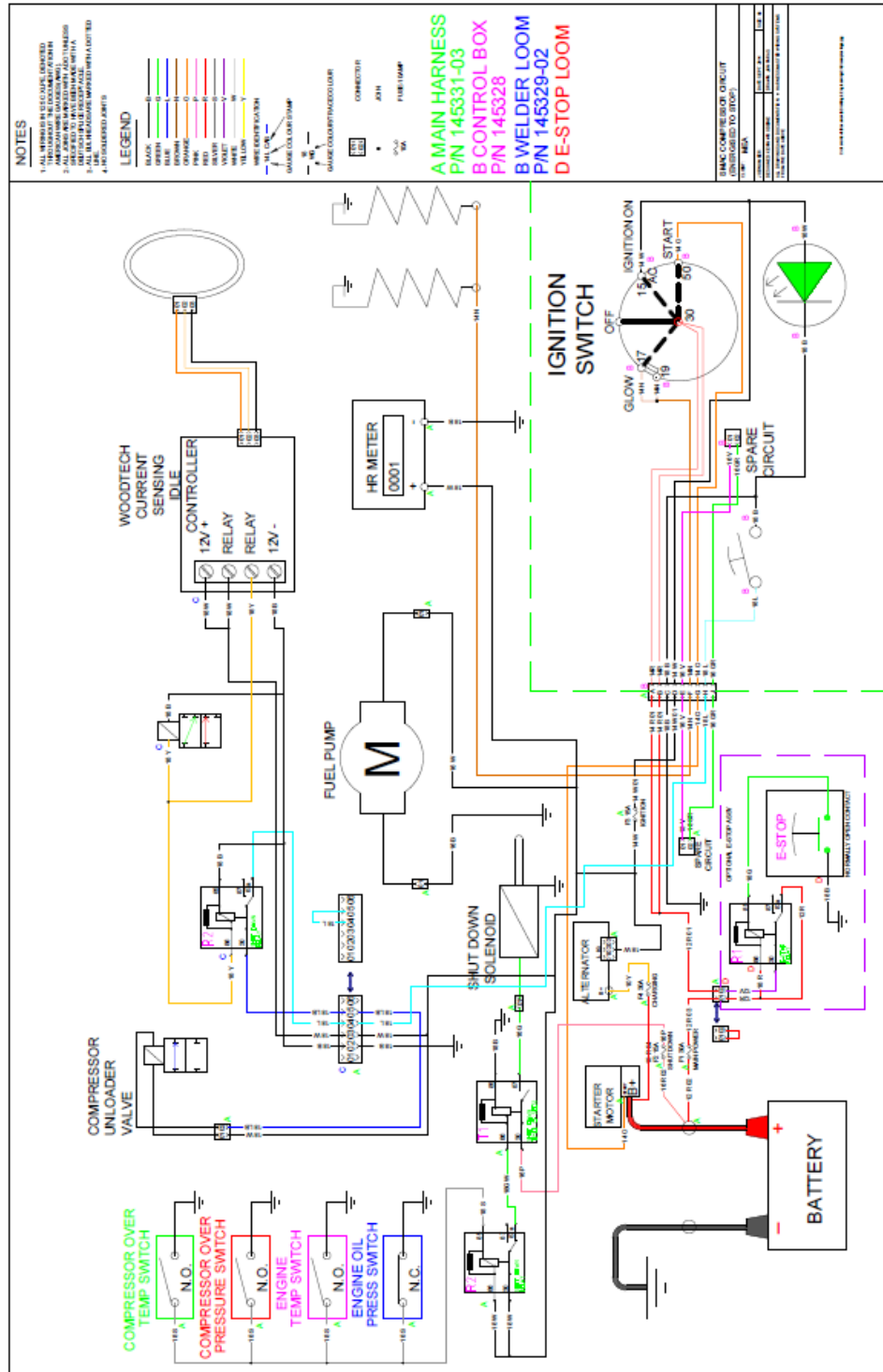

## DRAWINGS & ILLUSTRATIONS

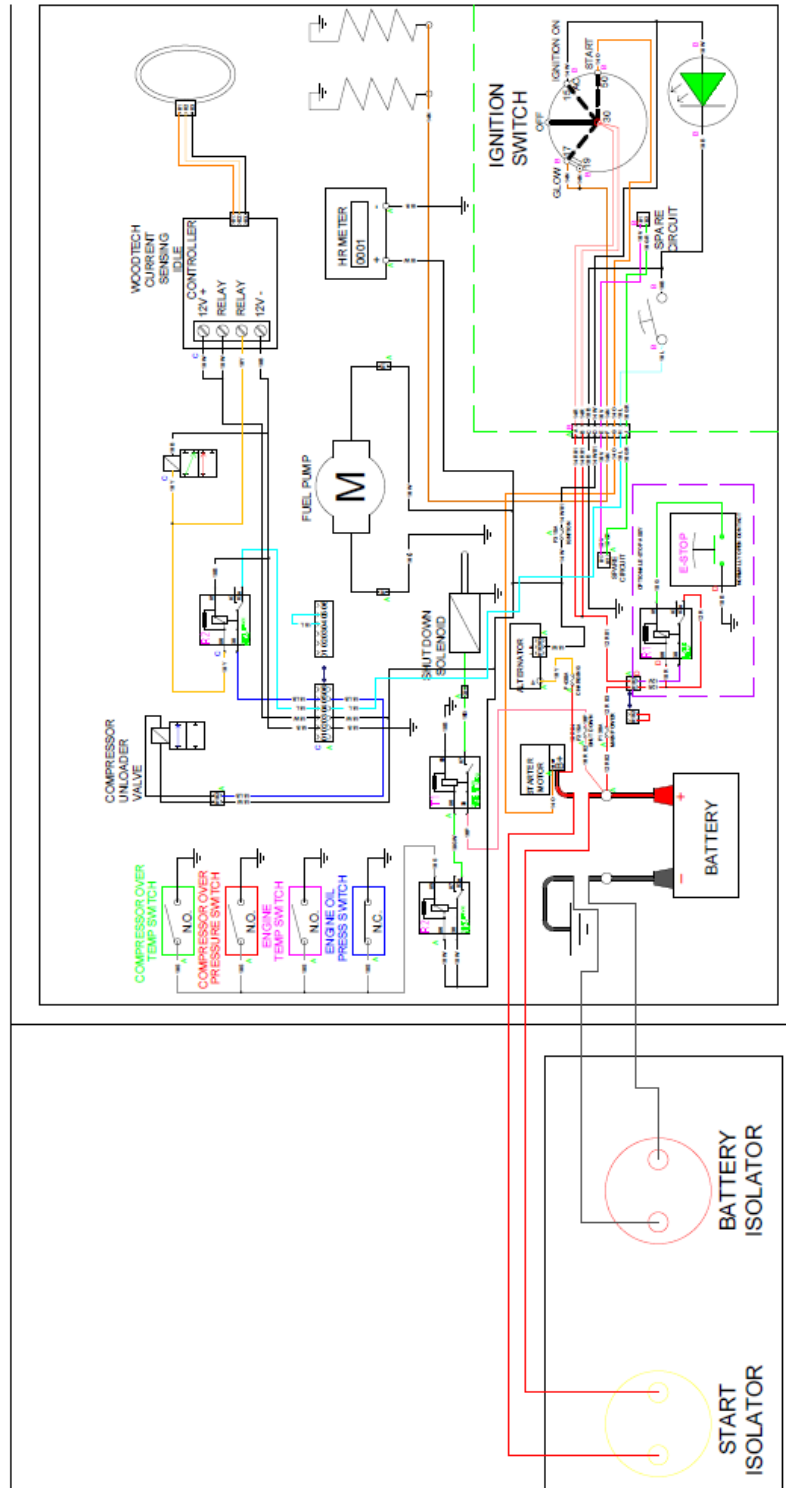

Document No 7208-D0001-01

Mobile Energy Australia Pty Ltd  
P: +61 7 3273 6803

39 Dulacca Street Acacia Ridge QLD 4110 Australia  
E: sales@mobileenergyaustralia.com.au

ABN 40 218 849 719  
www.mobileenergyaustralia.com.au

## DRAWINGS & ILLUSTRATIONS

---

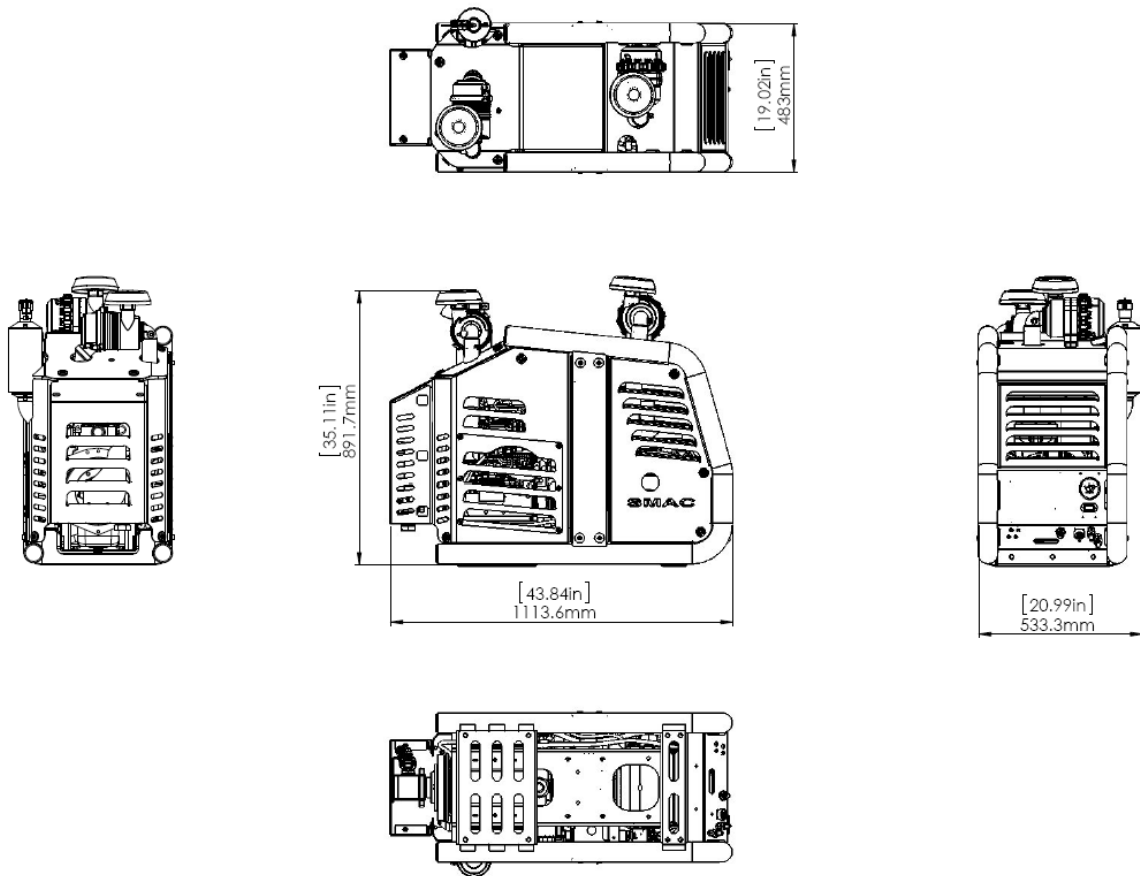

## DRAWINGS & ILLUSTRATIONS

---

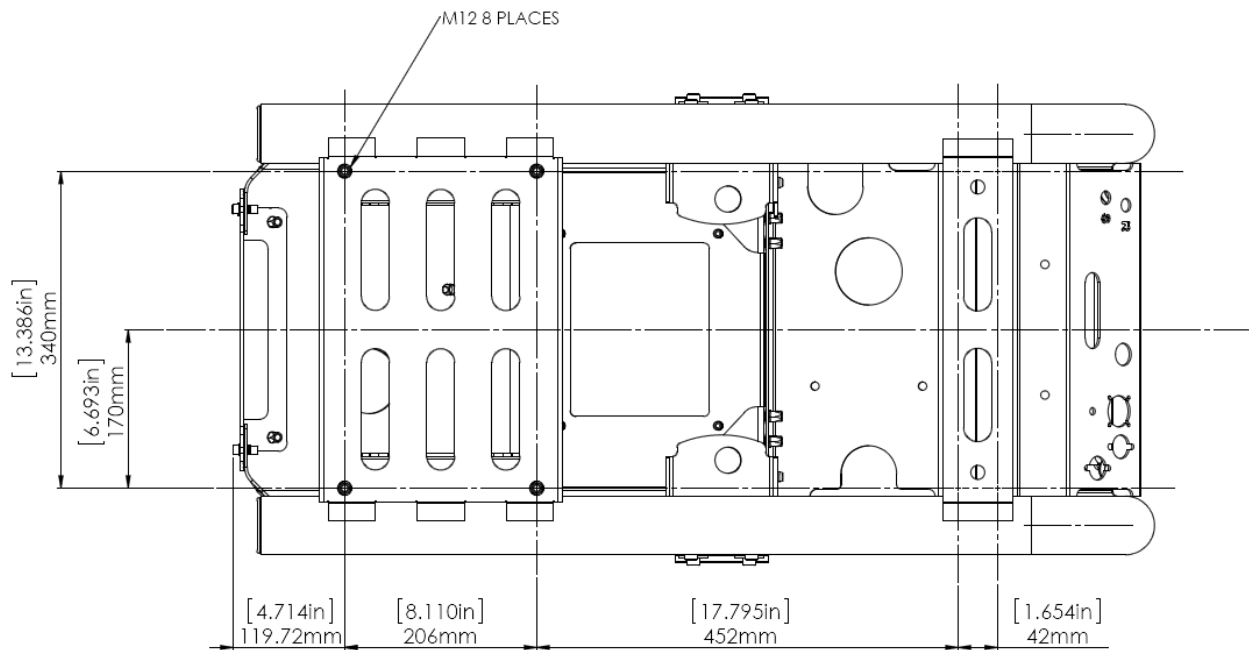

## DRAWINGS & ILLUSTRATIONS

---

### Hydraulic Pump Installation

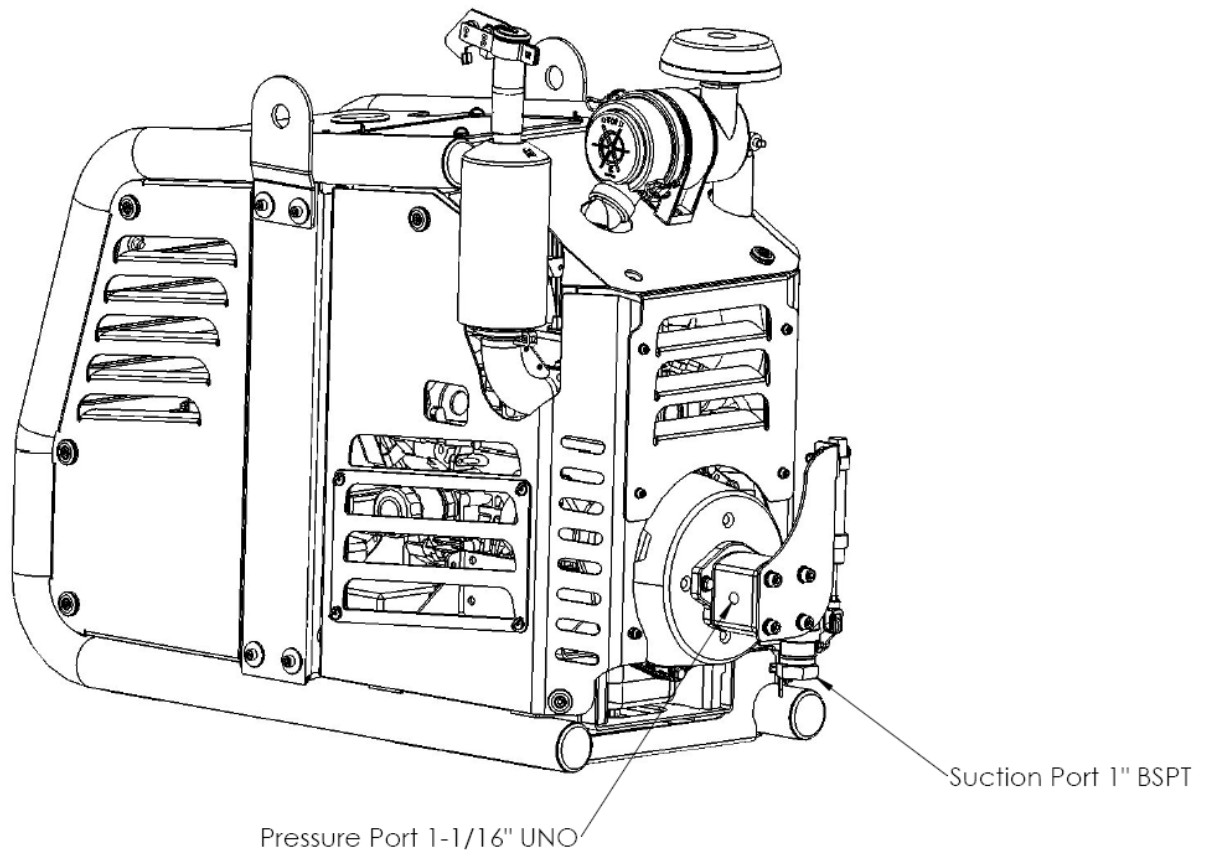

## WARRANTY

---

### 1 GENERAL PROVISIONS AND LIMITATIONS

- 1.1 Mobile Energy Australia (hereafter “MEA”) warrants to each original retail purchaser (hereafter “Buyer”) that such product(s) are, at the time of delivery to the buyer, free of manufacturing defects in material and workmanship.

### 2 NO WARRANTY IS MADE WITH RESPECT TO

- 2.1 Any product(s) which in the judgment of MEA has been subject to negligence, accident, improper storage, improper installation, improper application, improper operation or maintenance or has been repaired or altered by others without the written authority of MEA.
- 2.2 Components or accessories manufactured, warranted and serviced by others.
- 2.3 Damages caused by the lack of normal maintenance, service and repairs such as the replacement and service of filters and seals.
- 2.4 Damages caused by the lack of normal minimum action, such as adjustments and inspections, replacement of items, such as service filters, seals and service kits.
- 2.5 Consequential damages caused by product(s) failure.
- 2.6 Any product(s) if other than MEA’s genuine components are used in the product(s).
- 2.7 Normal wear and tear of product(s).

### 3 WARRANTY PERIOD

- 3.1 The warranty period will commence upon installation of the product(s). The returned registration form marks the date of installation. If the registration form is not received, the warranty period will be deemed to commence 30 days from date of shipment from MEA.
- 3.2 The Product(s) is warranted against manufacturer defects in materials and workmanship for a period of 12 months.
- 3.3 The compressor air end is warranted to be free from defects in material and workmanship for a period of two (2) years from the date of installation.
- 3.4 Components supplied under warranty shall be warranted for the remainder of the original warranty period.
- 3.5 MEA factory rebuilt components shall be warranted for a period of 6 months from date of shipment.

### 4 MEA OBLIGATIONS

- 4.1 The obligation of MEA is limited to repairing or replacing parts, during normal business hours, at an authorized service facility, any component, that in the judgment of MEA are defective.
- 4.2 The obligation of MEA is limited to replacement of faulty parts. No liability is accepted for any freight costs, consequential damages, injuries or expenses directly or indirectly related to the Product(s) failure.

## WARRANTY (continued)

---

### 5 BUYER OBLIGATIONS

- 5.1 Buyer shall notify MEA of the alleged defect within 10 days of initial discovery and return the allegedly defective component(s) within 30 days of initial discovery.
- 5.2 The Buyer must prepay all costs associated with the warranty.
- 5.3 The Buyer must return components claimed under this warranty to a facility designated by MEA for evaluation, to establish a claim under this warranty.
- 5.4 Buyer shall maintain and service MEA Product(s) in accordance with the MEA Product(s) Owner's

### 6 WARRANTY REGISTRATION VALIDATION

- 6.1 A registration form is provided to the Buyer with the product(s). The form must be fully completed by the Buyer and returned to MEA upon completion of the installation of the product(s) in order to validate the warranty. No warranty claims will be processed unless MEA has received a fully completed warranty registration form.

### 7 DISCLAIMER AND WARRANTY SERVICE

- 7.1 Any labor costs claimed in excess of MEA's set rate and/or times are not provided by this warranty. If applicable, any labor costs in excess of MEA rate schedules caused by, but not limited to, location or inaccessibility of the equipment, travel time or labor provided by unauthorized service personnel are not provided by this warranty.
- 7.2 This warranty is in lieu of all other warranties or obligations expressed or implied. MEA expressly disclaims all implied warranties of merchantability or fitness for a particular purpose.
- 7.3 Warranty claims must be pre-authorized by MEA, and the components returned via prepaid freight using the designated Returned Merchandise Authorization number and form.

### PLEASE NOTE:

Both the MEA Product Registration Form and the Kubota Engine Warranty Registration Form MUST be returned to MEA in the stamped, self-addressed envelope.

## WARNING!!!

**Failure to return PRODUCT WARRANTY REGISTRATION FORMS detailed above may result in the delayed processing of warranty claims.**





39 Dulacca Street  
Acacia Ridge,  
QLD 4110  
Australia  
Tel + 61 7 3273 6803  
Fax + 61 7 3272 3864  
ABN 40 218 849 719

## **MOBILE ENERGY AUSTRALIA - CONTACTS**

### **Management**

Managing Director – Rob Pulz

Office: 07 3273 6803

Mob: 0438 574 462

Email: [r.pulz@mobileenergyaustralia.com.au](mailto:r.pulz@mobileenergyaustralia.com.au)

### **Sales**

Email: [sales@mobileenergyaustralia.com.au](mailto:sales@mobileenergyaustralia.com.au)

Office: 07 3273 6803

### **Spare Parts**

BH Office: 07 3273 6803

Email: [spareparts@mobileenergyaustralia.com.au](mailto:spareparts@mobileenergyaustralia.com.au)

### **Service**

BH Office: 07 3273 6803

Email: [workshop@mobileenergyaustralia.com.au](mailto:workshop@mobileenergyaustralia.com.au)

---

Document No 7208-D0001-01

Mobile Energy Australia Pty Ltd  
P: +61 7 3273 6803

39 Dulacca Street Acacia Ridge QLD 4110 Australia

E: [sales@mobileenergyaustralia.com.au](mailto:sales@mobileenergyaustralia.com.au) [www.mobileenergyaustralia.com.au](http://www.mobileenergyaustralia.com.au)

ABN 40 218 849 719