



MEEA
MOBILE ENERGY AUSTRALIA
Specialists in vehicle mounted compressor & generator systems

SMARTPACK 180-H

(7232)

Owners & Operators Manual



**SERVICE MAINTENANCE AIR
COMPRESSOR – HYDRAULIC DRIVEN**

MEA Product Warranty Registration Form

**THIS FORM MUST BE COMPLETED AND
RETURNED WITHIN 30 DAYS OF INSTALLATION
OR
WARRANTY WILL BE VOID**

CUT HERE



MEGA Product Warranty Registration Form

This form must be completed and returned to MEGA at the time of Installation. Warranty will be void if this form is not received by MEGA within 30 days of installation.

MEGA Dealer Information

Company Name: _____

City: _____ State: _____ Country : _____

MEGA Installer Information

Company Name: _____

City: _____ State: _____ Country : _____

Installation Date: ____ / ____ / ____
 Day Month Year

Owner Information

Company Name: _____

Address: _____

City: _____ State: _____ Country : _____

Postcode: _____ Phone #: _____

Product Information

MEGA Serial Number: _____

Model Number: _____

Document No 7232-D0001-01

Table of Contents

PRODUCT SAFETY.....	2
PRODUCT SAFETY.....	3
INTRODUCTION.....	4
SPECIFICATIONS.....	5
OPERATING PROCEDURE.....	6
INSTALLATION.....	7
COMPRESSOR INFORMATION.....	9
DRAWINGS & ILLUSTRATIONS.....	18
WARRANTY.....	26

Both the MEA Product Warranty Registration form (located at the FRONT of this Manual) and the Kohler Engine Warranty Registration form (located at the back of this manual) are to be returned to MEA.

FAILURE TO RETURN EITHER FORM MAY RESULT IN THE PRODUCT WARRANTY BEING VOID.

PRODUCT SAFETY

(COMPRESSOR / COMPRESSED AIR)

MEA DISCLAIMS ANY AND ALL LIABILITIES FOR DAMAGE OR LOSS DUE TO PERSONAL INJURIES, INCLUDING DEATH, AND/OR PROPERTY DAMAGE INCLUDING CONSEQUENTIAL DAMAGES ARISING OUT OF ANY MEA SYSTEM NOT USED IN ACCORDANCE WITH THE OPERATOR INSTRUCTIONS.

ALL UNITS ARE SHIPPED WITH A DETAILED OPERATOR MANUAL. THIS MANUAL CONTAINS VITAL INFORMATION FOR THE SAFE USE AND EFFICIENT OPERATION OF THIS UNIT. CAREFULLY READ THE OPERATORS MANUAL BEFORE STARTING THE UNIT. FAILURE TO ADHERE TO THE INSTRUCTIONS COULD RESULT IN SERIOUS BODILY INJURY OR PROPERTY DAMAGE.

Care is required when working with an air compressor or compressed air. Compressed air is one of the many ways energy can be stored. Releasing the stored energy in an uncontrolled manner can result in catastrophic consequences. Death and permanent disability are all possibilities that can occur. The following are suggested as minimum precautions to be used when operating the SMARTPACK Air Compressor. It is important that each work site engages in a risk analysis of that site and produces procedures in order to minimise injury to their employees. Health and Safety Regulations today require that this is a compulsory process to be carried out on each site. These, with site specific designed safety precautions will help to reduce accidents, personal injury and loss of life. It is the responsibility of the employer to ensure that the work site is safe for the employees.

SAFETY WHEN OPERATING AN AIR COMPRESSOR

- Do not bypass or disable the oil temperature sensor.
- Do not expose the tank or compressor to extreme heat.
- Do not perform any service or repairs until the system has been completely relieved of air pressure.
- Maintenance and repairs on the system should only be done by qualified personnel.
- Do not operate the compressor while driving.
- Do not tamper with the pressure relief valve.
- Run the system at idle speed and under no load conditions for 2 to 3 minutes before turning the system off to allow system cooling and lubrication to occur.
- Follow safe work practices, wear the appropriate safety equipment when operating air-powered equipment, particularly eye and hearing protection.
- Avoid contact with rotating components, ensure all safety guards are in place.
- Avoid all contact with pressurized air. If it penetrates your skin, it can enter your blood stream and cause death.
- To prevent compressor explosion or fire, make sure that the air entering the compressor is free of flammable vapors.
- Vaporized oil propelled by high pressure is an explosive mixture.
- Do not breathe the compressor air, vaporized oil is a respiratory hazard.
- Stay clear of all moving parts when the system is operating.
- Follow safety procedures for tyre service operations as set by the authority.

PRODUCT SAFETY

HYDRAULIC SAFETY

ALL HYDRAULIC EQUIPMENT MUST BE TREATED WITH EXTREME RESPECT AND CARE. AS THE WORKING FLUID IS UNDER EXTREME PRESSURE, UP TO 5000PSI, WITH HIGH FLOW RATES GENERATING HIGH HEAT, ALL APPROPRIATE SAFETY PRECAUTIONS MUST BE TAKEN IN TO ACCOUNT AND SAFETY EQUIPMENT MUST BE WORN IF IN CONTACT WITH THE EQUIPMENT UNDER OPERATION. ALL LEAKS, NO MATTER HOW MINOR, MUST BE RECTIFIED IMMEDIATELY AND ANY WEAR IN THE HOSES MUST BE ADDRESSED AND EQUIPMENT REPLACED. HYDRAULIC INJECTION IS DANGEROUS AND LIFE THREATENING AND EVEN A PINHOLE LEAK WILL BLANKET AN ENTIRE ENCLOSED SPACE VERY QUICKLY WITH HAZERDOUS VAPORISED HYDRAULIC OIL MIST.

INTRODUCTION

This MEA vehicle mounted air compressor system utilizes the vehicles engine to power the installed compressor to supply compressed air at the specified flow rate and pressure.

Only those who have been trained and delegated to do so, and who have read and understand the operation and installation procedures should install MEA compressor systems.

This Manual contains vital information of the compressor system and its integration into the existing vehicle system to ensure that it is operated in a safe and efficient manner.

SPECIFICATIONS

Compressor Model: SMARTPACK 180H

Compressor Type: Oil flooded rotary screw compressor

Control: 24V/12V Electronic Control

Maximum Air Delivery: 210cfm @ 150psi

Pressure Regulation: Mechanical Inlet control valve modulates flow in response to demand

Safety Features: 200 PSI relief valve in compressor sump
Temperature safety sensor in compressor
Rapid blow-down valve to discharge system pressure on shutdown

Lubrication: MEA Certified and Approved Oil

Filters: Paper-type replaceable air filter
Spin-on type oil filter
Coalescing separator element

OPERATING PROCEDURE

WARNING

**CAREFULLY READ THE OPERATING INSTRUCTIONS BELOW.
FAILURE TO ADHERE TO THE FOLLOWING COMPRESSOR
OPERATING INSTRUCTION COULD RESULT IN SERIOUS INJURY.**

1. Check Oil Level.
2. Check Hoses and fittings for leaks.
3. Check Loose/damaged hoses.
4. Check Air Filter for Blockage.
5. Check the Safety circuit switch operation (Reset Switch).
6. Switch on the vehicle and activate the vehicle flow control (turn PTO on).
7. Turn on the compressor either at the control box or in the cab, ensure it is in the unloaded state (check load/unload switch).
8. Turn the unload/load switch to load and check the compressor builds pressure to the regulated pressure setting.
9. Plug an air tool into the air outlet and operate checking that the compressor works as required.
10. When finished using the compressor for the job, switch to unload.
11. Switch off at either the control box or in Cab, and switch off the vehicle.
12. It is good practice to check for any visible signs of hydraulic fluid leakage and or compressor fluid leakage after each use.

INSTALLATION

The SMARTPACK 180H is designed as an integrated compressor system for connection to an existing hydraulic system. The SMARTPACK 180H only requires connection of a pressure line in, a return line out and a connection of the motor drain line to the tank line.

For particular Air Flow requirements the following table can be used as a reference when setting up the compressor Hydraulic Oil Flow required.

When setting up the Compressor unit, ensure there is a safety mechanism in place to prevent any excessive flow or pressure into the compressor hydraulic circuit.

MEA will not warrant any damage caused to the compressor from the existing hydraulic system.

1. Install SMARTPACK 180H into position on the vehicle using 6 x min. M12 x 1.75 Grade 8.8 Fasteners.
2. Install the hydraulic lines, i.e. pressure in, return out and drain line.
3. If purchasing the Frameless version only; install the cooler and connect the compressor cooler lines to both the cooler and the compressor, see Appendix for port identification.
4. Connect the electrical control box to the vehicle; be sure to place an in-line weatherproof fuse (30A – 12V and 20A – 24V) within 300mm of the vehicle battery. Ensure the control box is compatible with your vehicles voltage rating.
5. Connect the pressure gauge line to the SMARTPACK 180H, see circuit diagram.
6. Connect the terminals of the electrical loom as per the circuit diagram relevant to your vehicle to both the vehicle and the SMARTPACK 180H.
7. Check the level of oil in the compressor.
8. Switch on the vehicle, turn on the compressor at the control box and test the hydraulic solenoid for operation.
9. Turn the unload/load switch to load and check the compressor builds pressure to the regulated pressure setting.
10. Plug an air tool into the air outlet and operate checking that the compressor works as required, run for 10mins.
11. Unload the compressor, switch off the control box, switch off the vehicle and check for any visible signs of hydraulic fluid leakage.
12. When cool (safe to touch), and switched off, re-check compressor oil level.

SMARTPACK 180-H

Motor Displacement CC/Rev 61 Gear Ratio 1: 2.31
Nominal Operating Pressure 180 Bar

CFM	HYD MOTOR RPM	M ³ /MIN	LOBE SPEED	HP@ 100 PSI	KW @100 PSI	OIL FLOW LPM
50	742	1.42	1715	13.1	9.8	48
61	891	1.73	2059	15.8	11.8	57
84	1188	2.38	2745	21.3	15.9	76
107	1485	3.03	3431	27.2	20.3	95
130	1782	3.68	4117	33.7	25.1	114
153	2079	4.33	4803	39.7	29.6	134
165	2228	4.67	5146	42.9	32	143
180	2424	5.10	5600	47.1	35.1	156
187	2547	5.30	5883	49.8	37.1	164
199	2674	5.64	6176	53.2	39.7	172
210	2822	5.95	6519	56.9	42.4	181
221	2971	6.26	6862	60.5	45.1	191

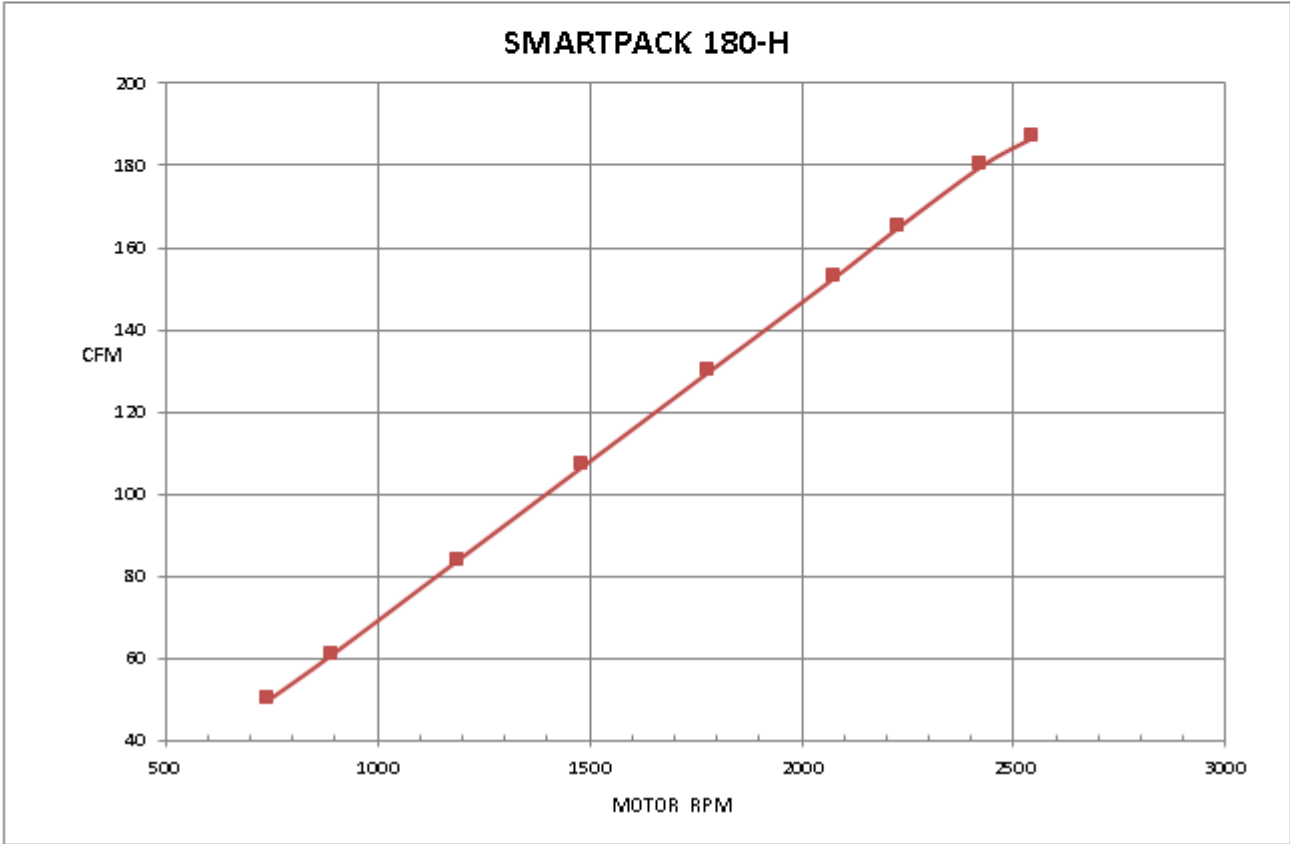

COMPRESSOR INFORMATION

Type of machine	Oil-injected rotary screw compressor			
Drive	Direct or belt			
Rotor dimension: Outside main diameter	111.3	mm	4.4	in
Rotor dimension: • L/D	1.55			
Air capacity (ISO 1217 annex B 2009)	0.86-6	m ³ /min	38.8-211.8	cfm
Max Working Pressure	13	bar g	188.5	psi g
Min Working Pressure	5	bar g	72.5	psi g
Oil injected quantity	50-70	l/min	13.2-18.5	gal/min
Max input Power	37	kW	49.6	hp
Max main rotor speed	6700	rpm	6700	rpm
Min main rotor speed	1450	rpm	1450	rpm
Max outlet air/oil temperature	105	°C	221	°F
Environment max. Temperature	45	°C	113	°F
Environment min. Temperature *	0	°C	32	°F
Thermostatic temperature	55-71-83	°C	131-159.8-181.4	°F
Gear transmission	0.95	min	2.55	max
Oil nipple size	¾ Gas - ¾ 16UNF – 1" 12UNF			
Separator nipple	M24x195mm – M22x115mm			
Operating pressure	8bar – 10bar – 13bar			
Materials	Air-end body: cast iron; Body valve: Aluminium; Internal parts: Aluminium galvanized, stainless steel, PTFE, viton, Xylan			
Weight	112	Kg	246.91	lb

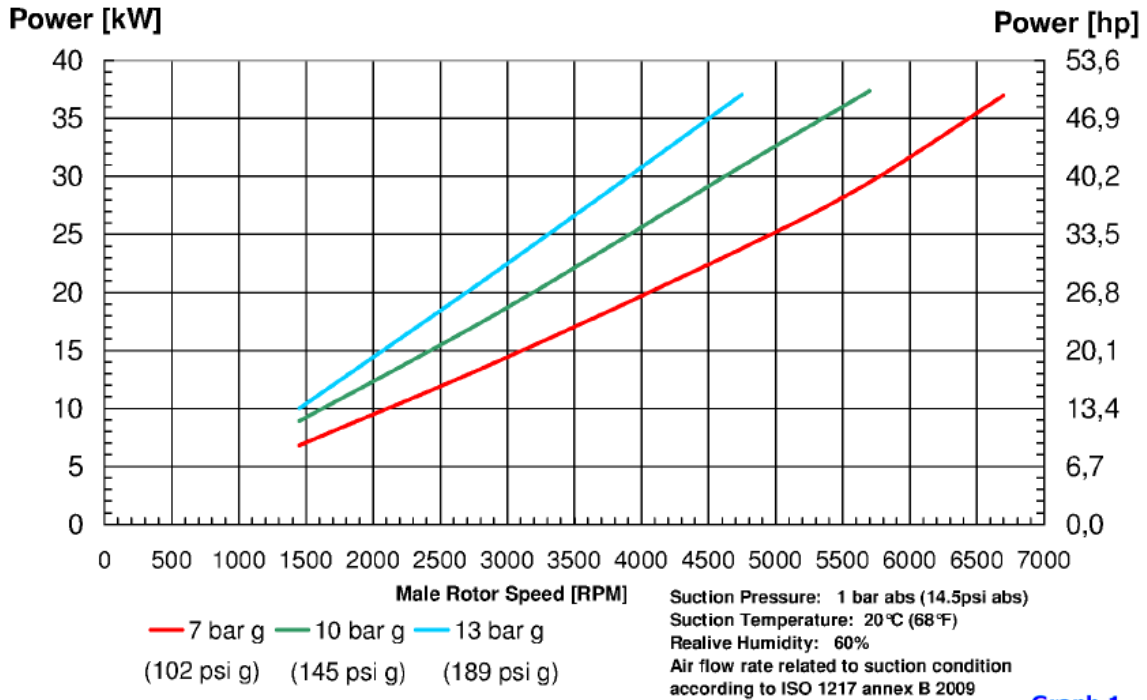

Graph 1

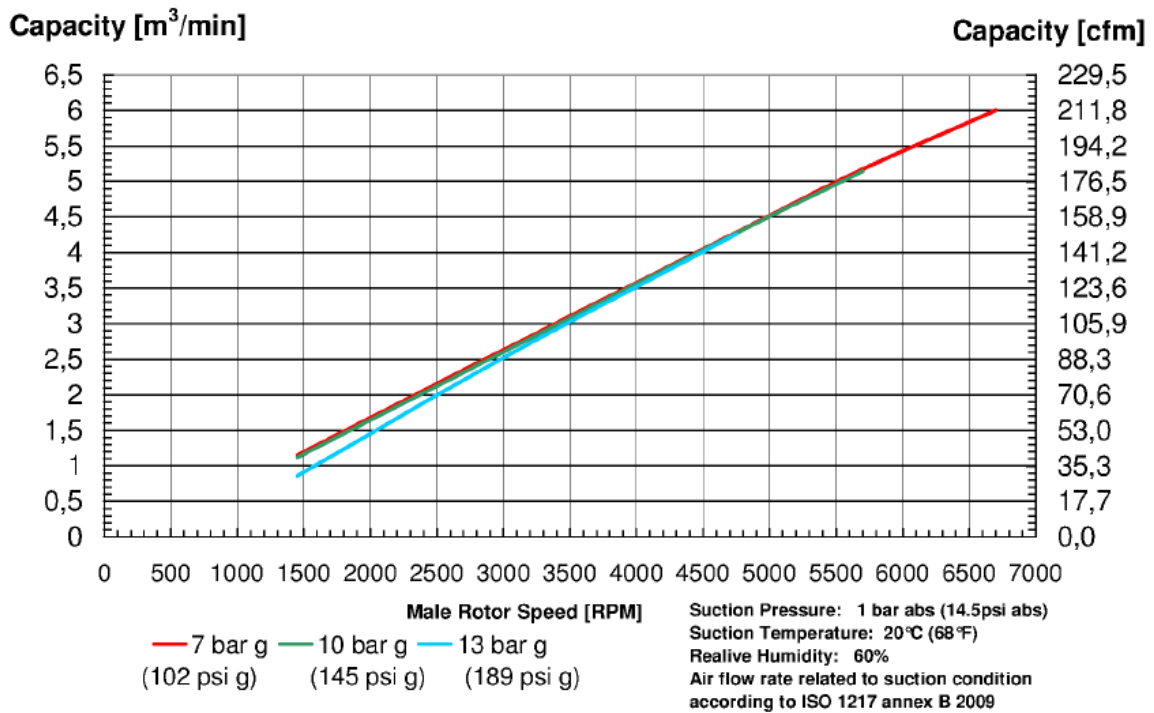

Graph 2

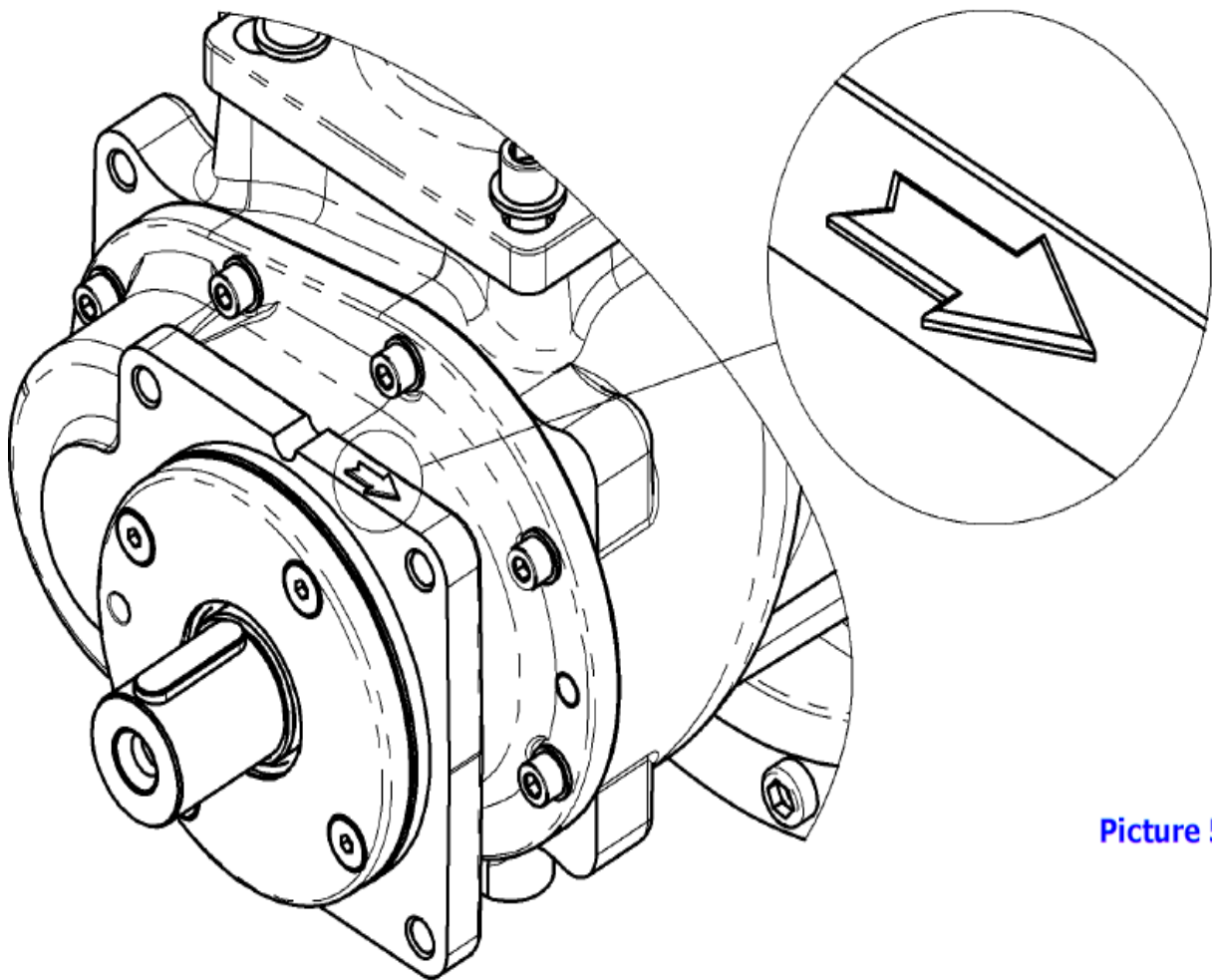

Picture 5

VISORE LIVELLO OLIO OIL LEVEL VIEWER

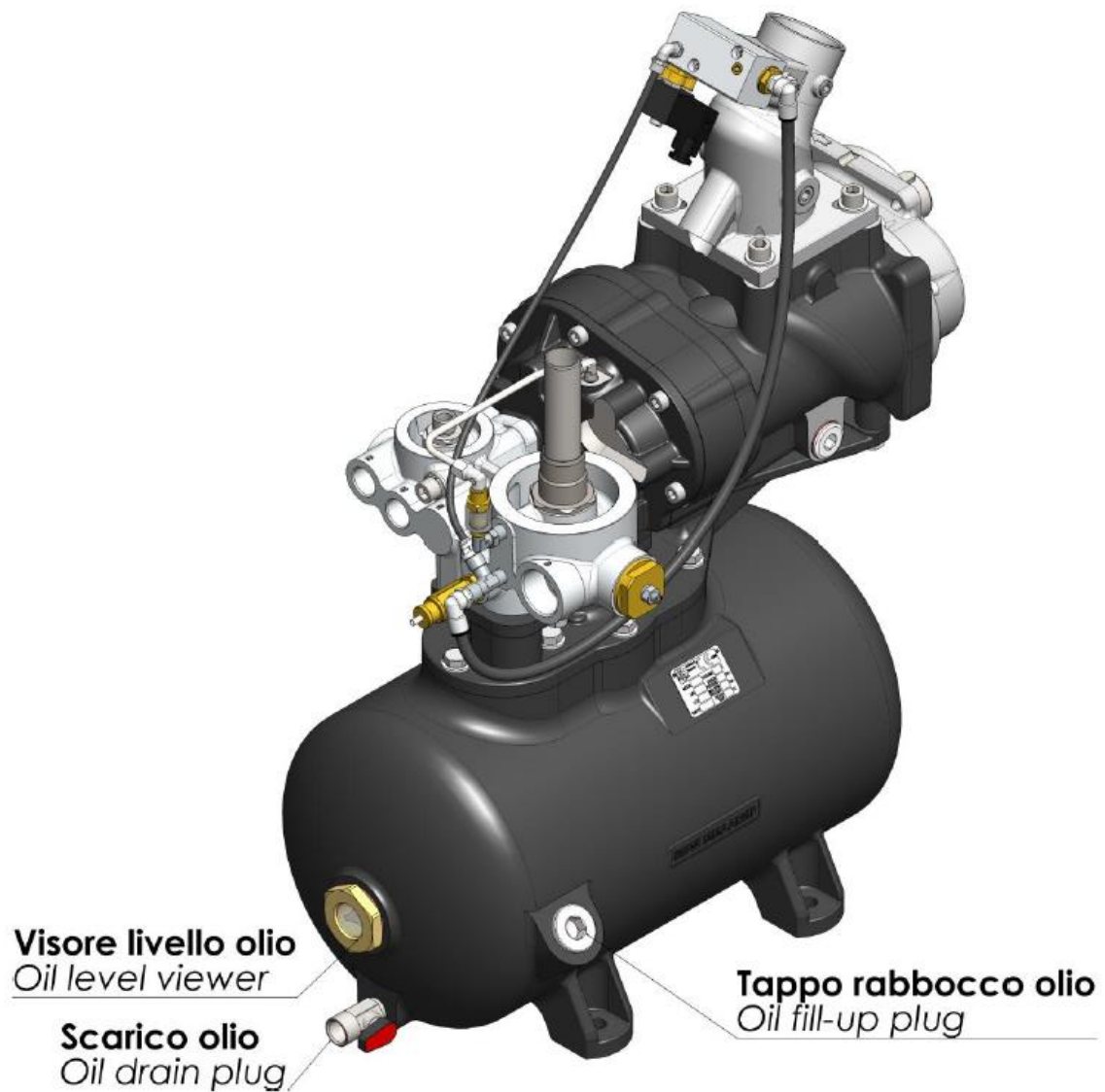
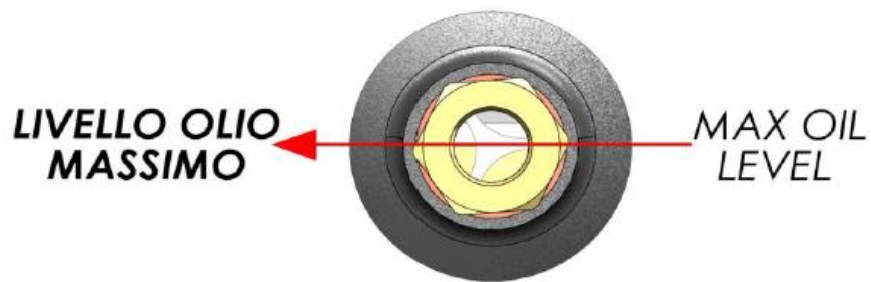

For a correct maintenance of a Pack Smart, the spare parts kits shown here below in the Pictures are recommended.

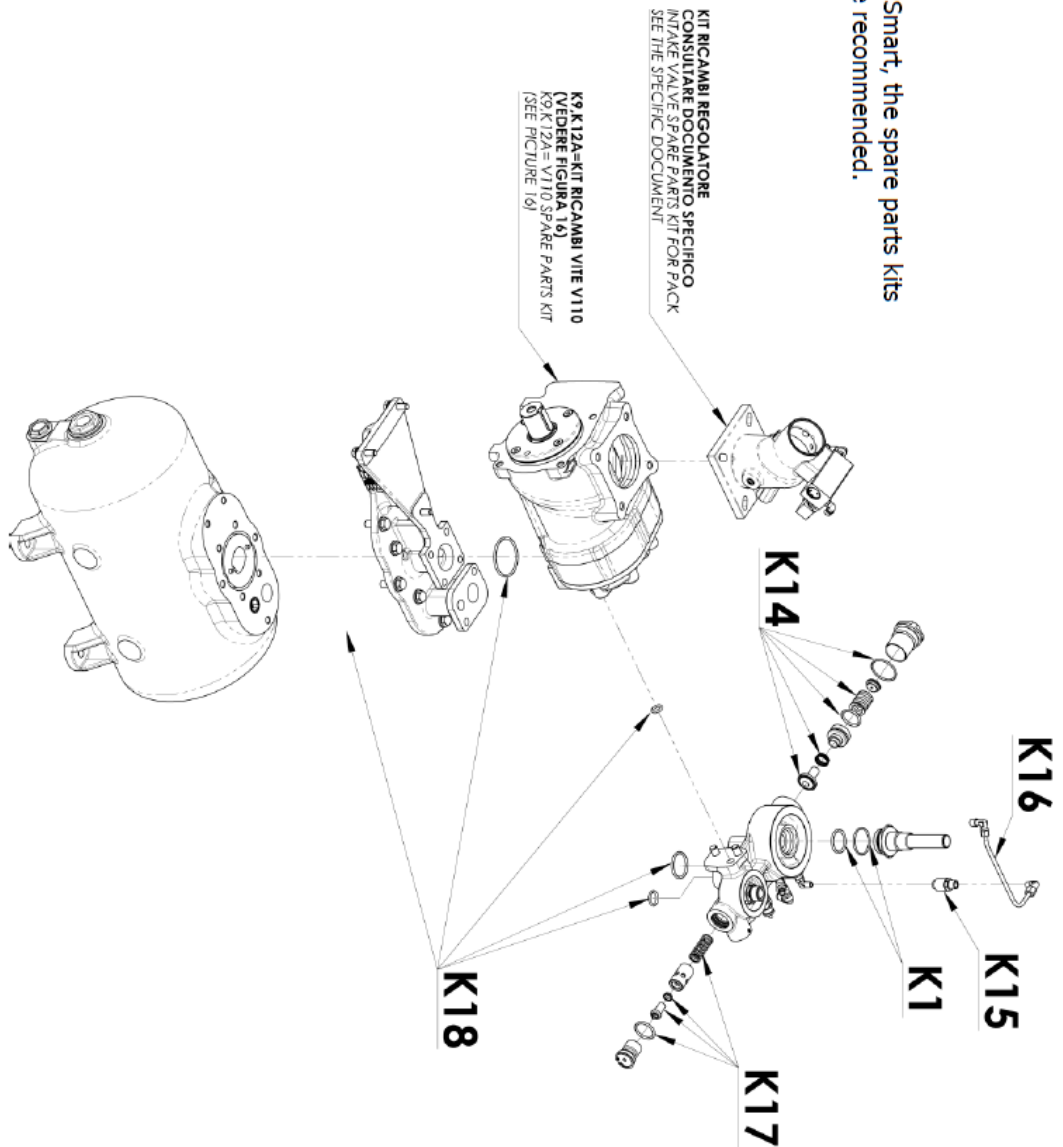

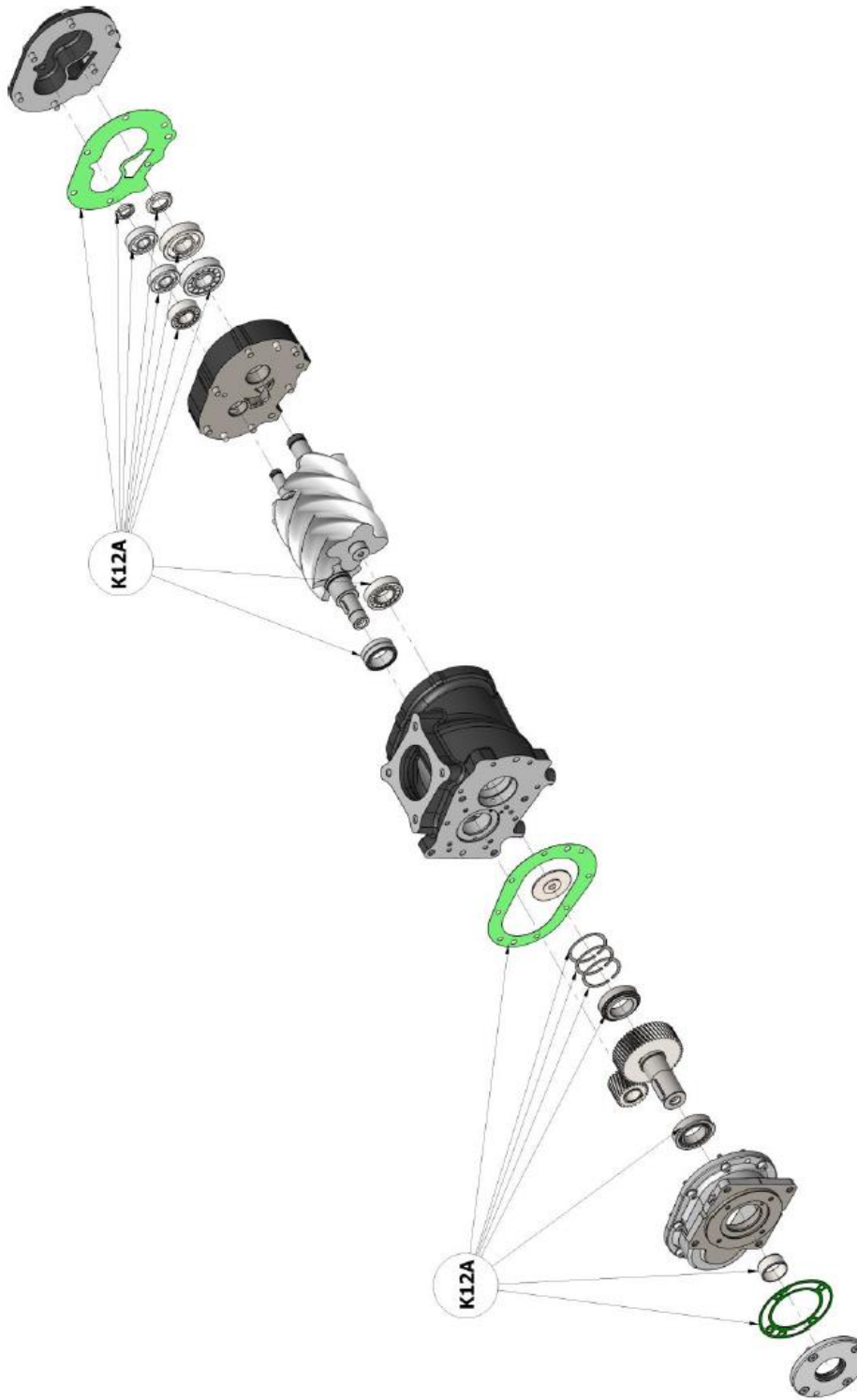

Extraordinary maintenance kits and their part numbers with all the instructions needed to carry out an appropriate maintenance are included in the technical specifications of the air-end requested and are available on demand.



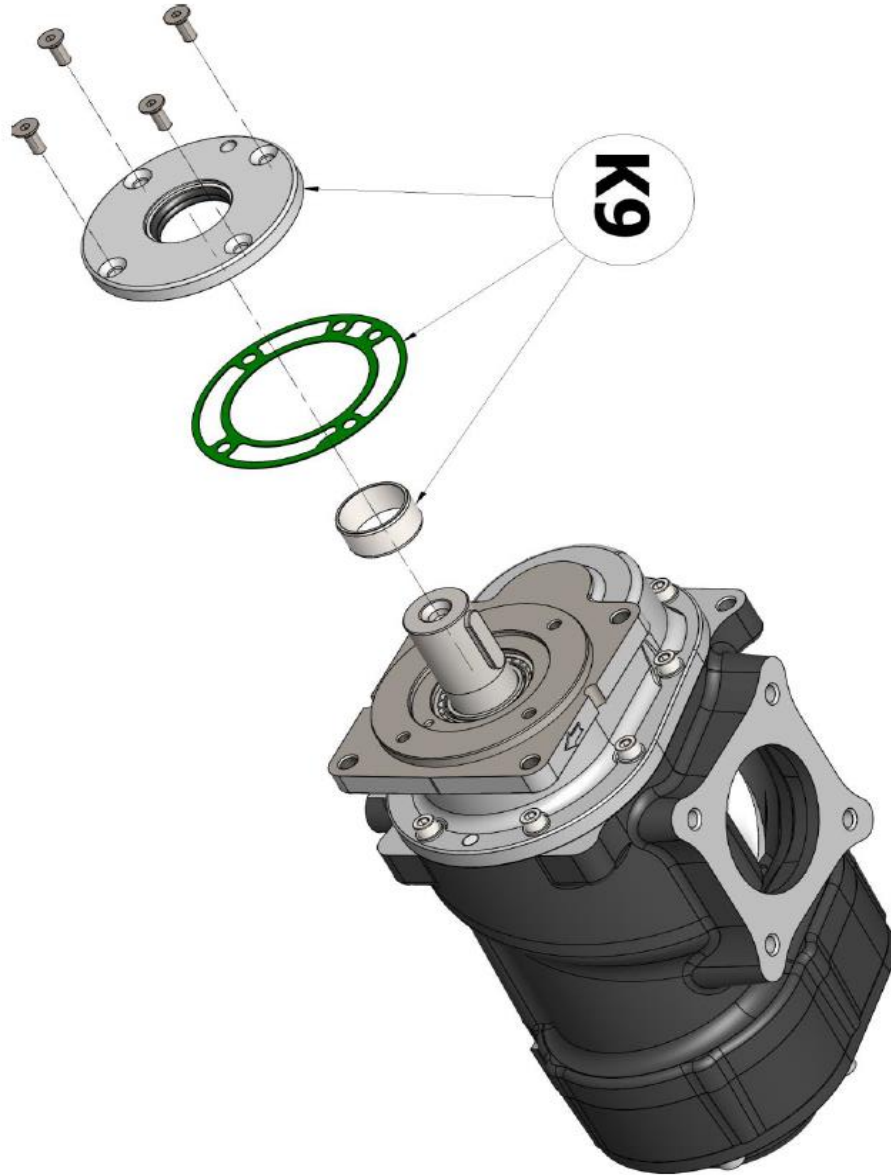

⚠ Extraordinary maintenance kits and their part numbers with all the instructions needed to carry out an appropriate maintenance are included in the technical specifications of the air-end requested and are available on demand.

SYMPTOMS	PROBABLE CAUSE	CORRECTIVE ACTION
The compressor does not load.	1-The intake valve remains closed.	1-Check the valve. If necessary, replace the damaged parts with K9 spare parts kit.
	2-The solenoid valve does not work accurately	2-Check the solenoid valve. If necessary, replace it.
	3-Losses on the pressure line.	3-Check pipes and cables. If necessary, replace them.
During idling phase, the compressor does not discharge pressure from separator tank	1-The solenoid valve does not work accurately.	1-Check the solenoid valve. If necessary, replace it.
	2-The calibrated nozzle is clogged.	2-Remove the calibrated nozzle. Clean or replace it.
Compressor capacity or pressure lower than usual standard.	1-The air filter is clogged.	1-Remove the air filter. Clean or replace it.
	2-The intake valve does not open.	2-Check the valve. If necessary, replace the damaged parts with K9 spare parts kit.
	3-Air loss from safety valve.	3-Replace the valve.
Compressor keeps on loading over working pressure: safety valve opens	1-The solenoid valve does not work accurately.	1-Check the solenoid valve. If necessary, replace it.
	2-Clogged separator filter.	2-Replace the separator filter.
Compressor overheating.	1-Insufficient cooling.	1-Check the cooling system. Check coolant level on tank.
	2-Dirty oil	2-Replace it with new oil.
	3-Oil level is too low.	3-Check coolant level on tank and if necessary, add oil.
	4-Clogged-up cooler or pipe connection	4-Clean cooler and pipes.
	5-The thermostatic valve does not work correctly.	5-Check the thermostatic valve. If necessary, replace the damaged parts with K3 spare parts kit.
	6-Clogged oil filter	6-Replace the oil filter.
SYMPTOMS	PROBABLE CAUSE	CORRECTIVE ACTION
During unloading phase, pressure increases up to safety valve opening	1-The intake valve remains open.	1-Check the valve. If necessary, replace the damaged parts with K9 spare parts kit.
	2-The calibrated nozzle is clogged.	2-Remove the calibrated nozzle. Clean or replace it.
Oil leakage from intake valve only when the machine is switched off: oil soaked-up air filter	1-The intake valve does not work properly (does not close)	1-Check the valve. If necessary, replace the damaged parts with K9 spare parts kit.
	2-The no-return valve of intake valve does not work correctly.	2-Check it and clean it.
Oil soaked-up air filter during unloading phase	1-Too high level of oil in the tank	1-Check oil level on separator tank (see the chapter 6).
	2- Clogged separator filter	2- Replace the separator filter.
	3-The recovery oil viewer is dirty or does not work appropriately.	3 -Clean it or if necessary, replace the damaged parts with the K11 spare parts kit. If separator filter is clogged up, replace it.
The compressor remains under loading phase.	1-The intake valve does not work properly (does not close)	1-Check the valve. If necessary, replace the damaged parts with K9 spare parts kit.
Rotor seizure	1-Unknown particles inside.	1-Call MEA technical support.
	2-Insufficient lubrication.	2-Call MEA technical support.

SPARE PARTS

Part Number	Description
1008-P0024	AIR FILTER ELEMENT
1008-P0029	SPIN ON COALESCER
1008-P0078	OIL FILTER

IMPORTANT:
PLEASE CONTACT MOBILE ENERGY AUSTRALIA FOR MORE INFORMATION IF YOU HAVE ANY QUESTIONS REGARDING THE SETUP AND OPERATION OF THE SMARTPACK RANGE OF PRODUCTS.

DRAWINGS & ILLUSTRATIONS

A) HARNESS SMARTPACK 180H FRAMED 12V AND 24V

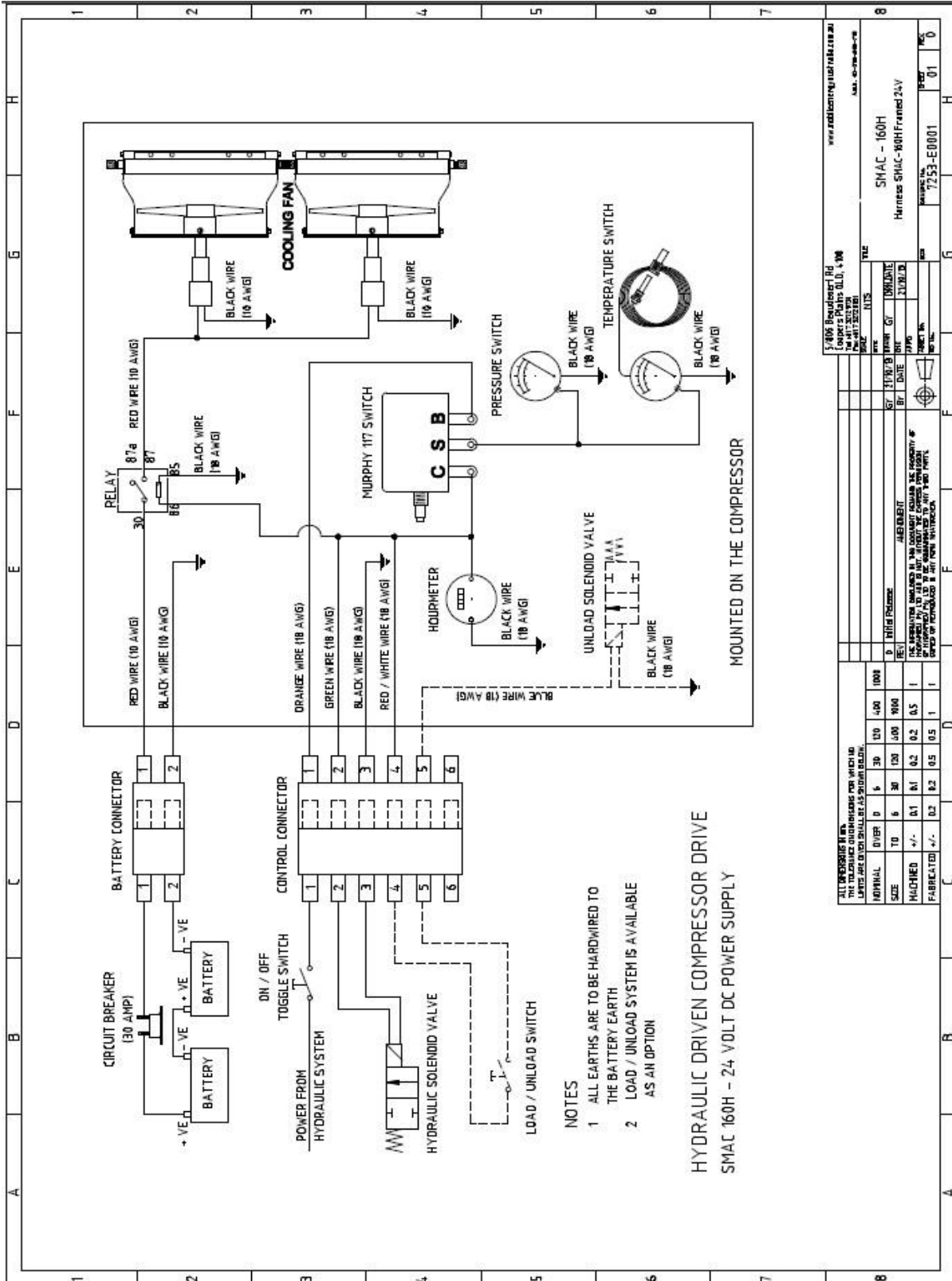

B) HARNESS SMARTPACK 180H FRAMELESS 12V AND 24V

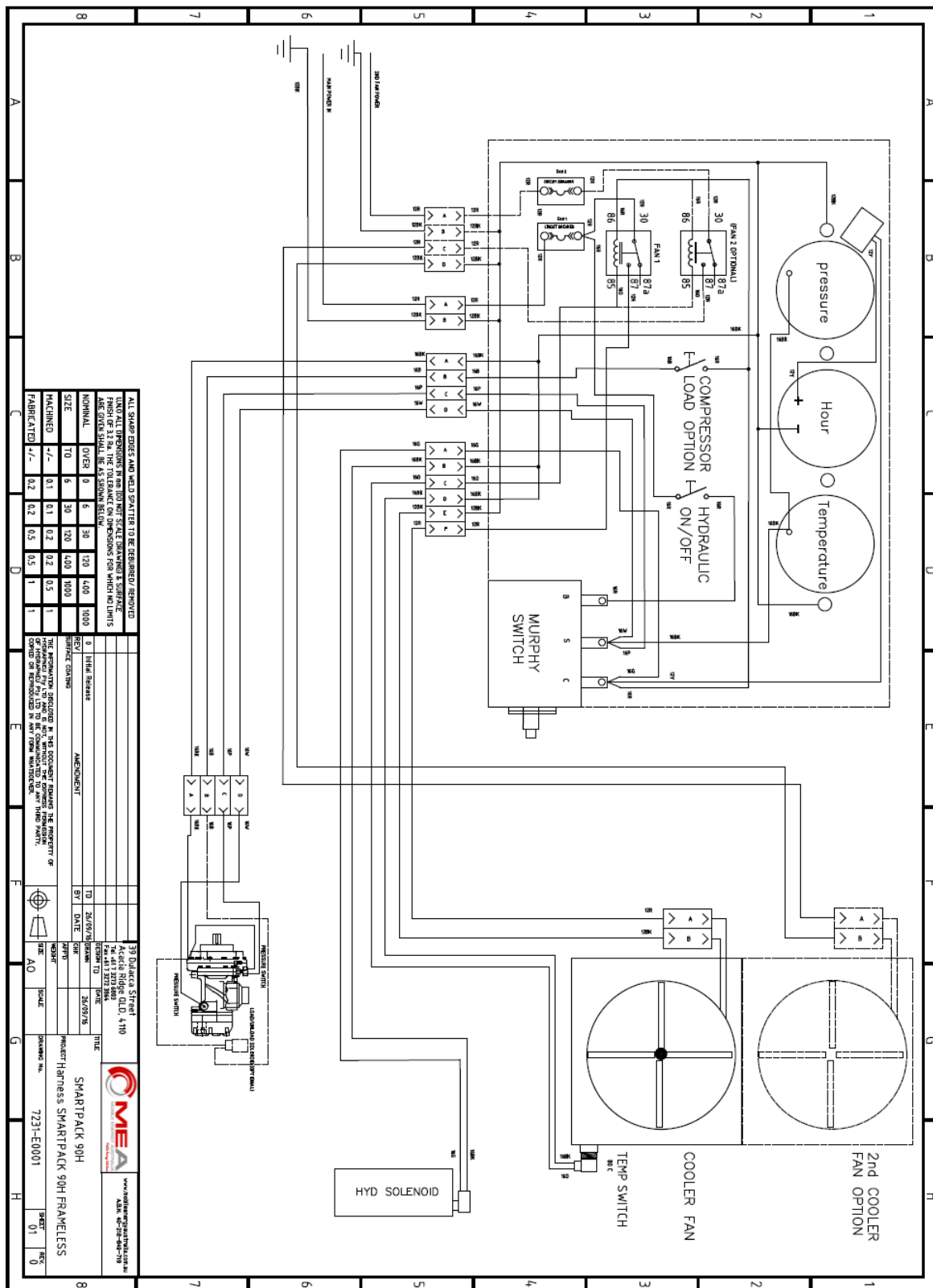

C) SMARTPACK -H Compressor Remote Electronic Control Wiring 12 or 24V

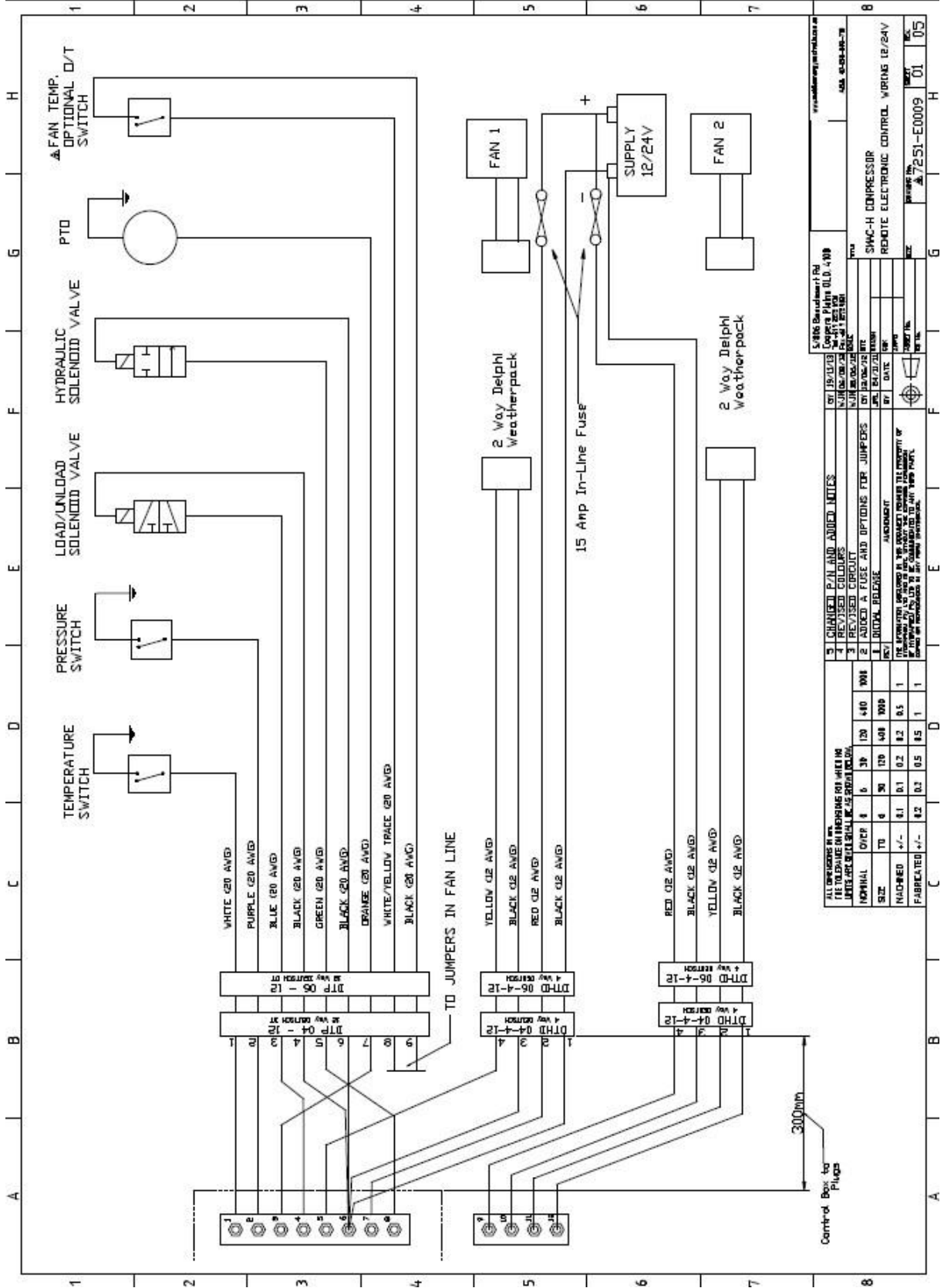

D) SMARTPACK -180H - GENERAL DRAWINGS

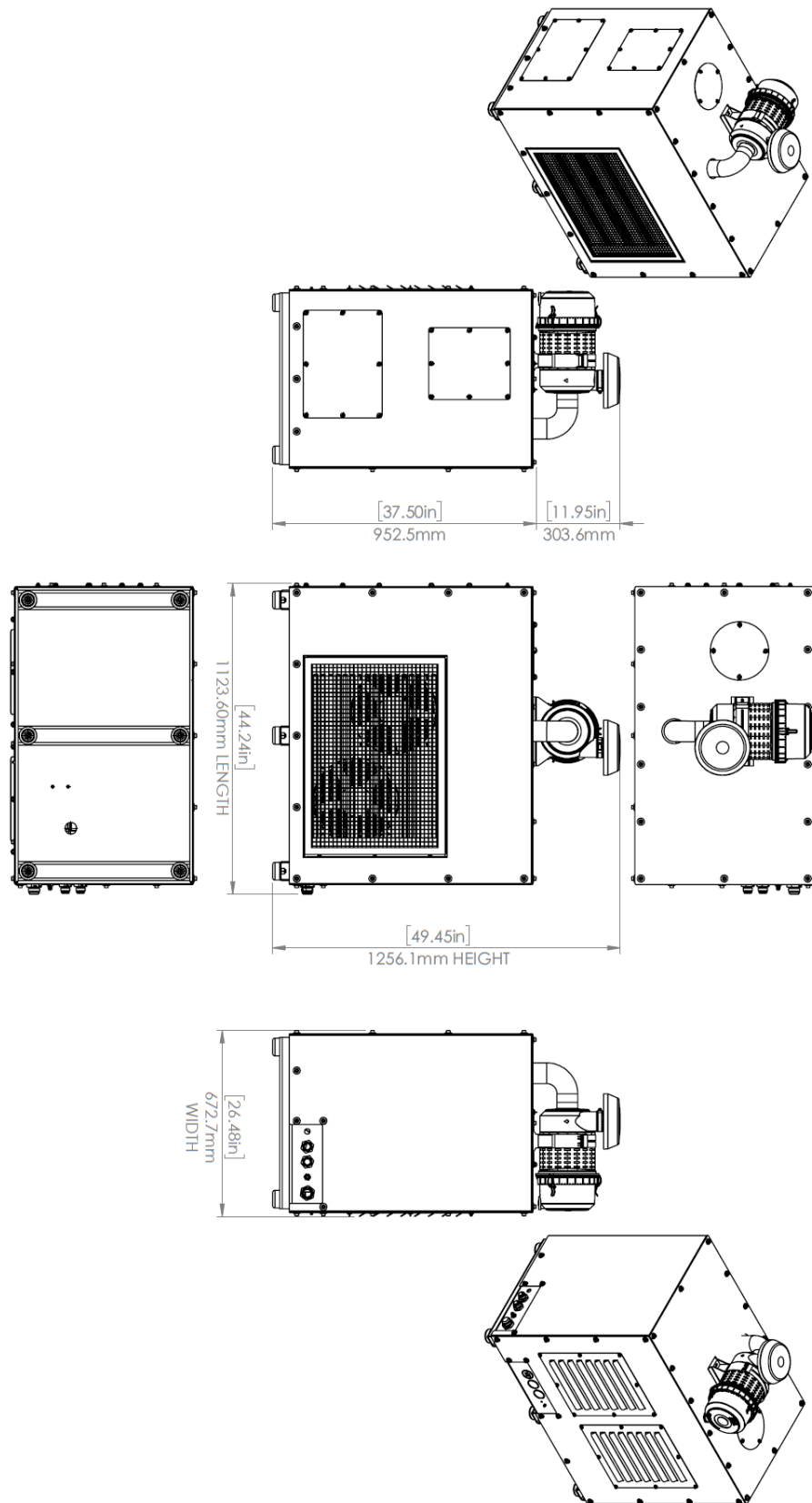

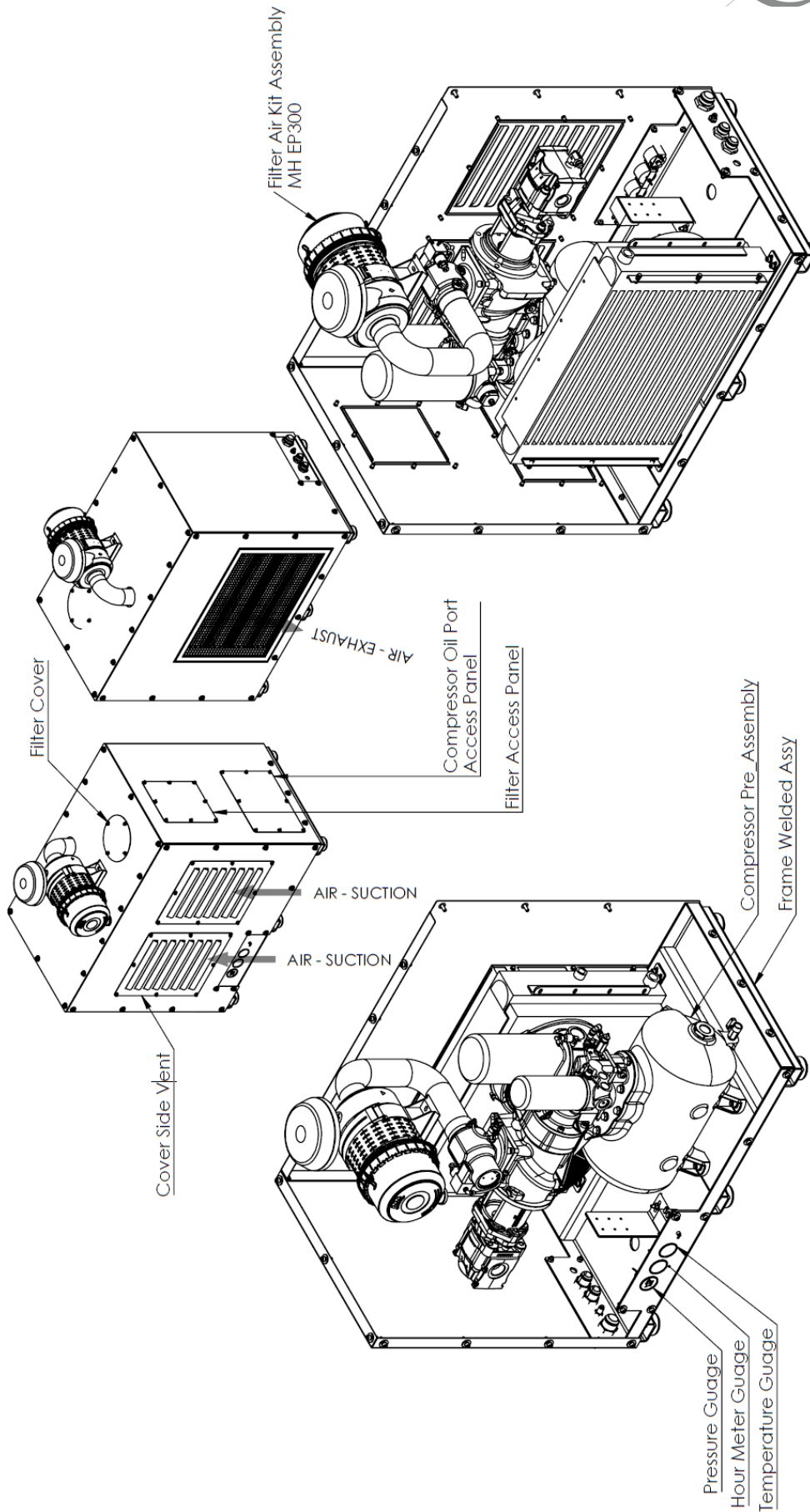

cover panels are not shown fully for clarity

cover panels are not shown fully for clarity

E) SMARTPACK -180H - MOUNTING DRAWINGS

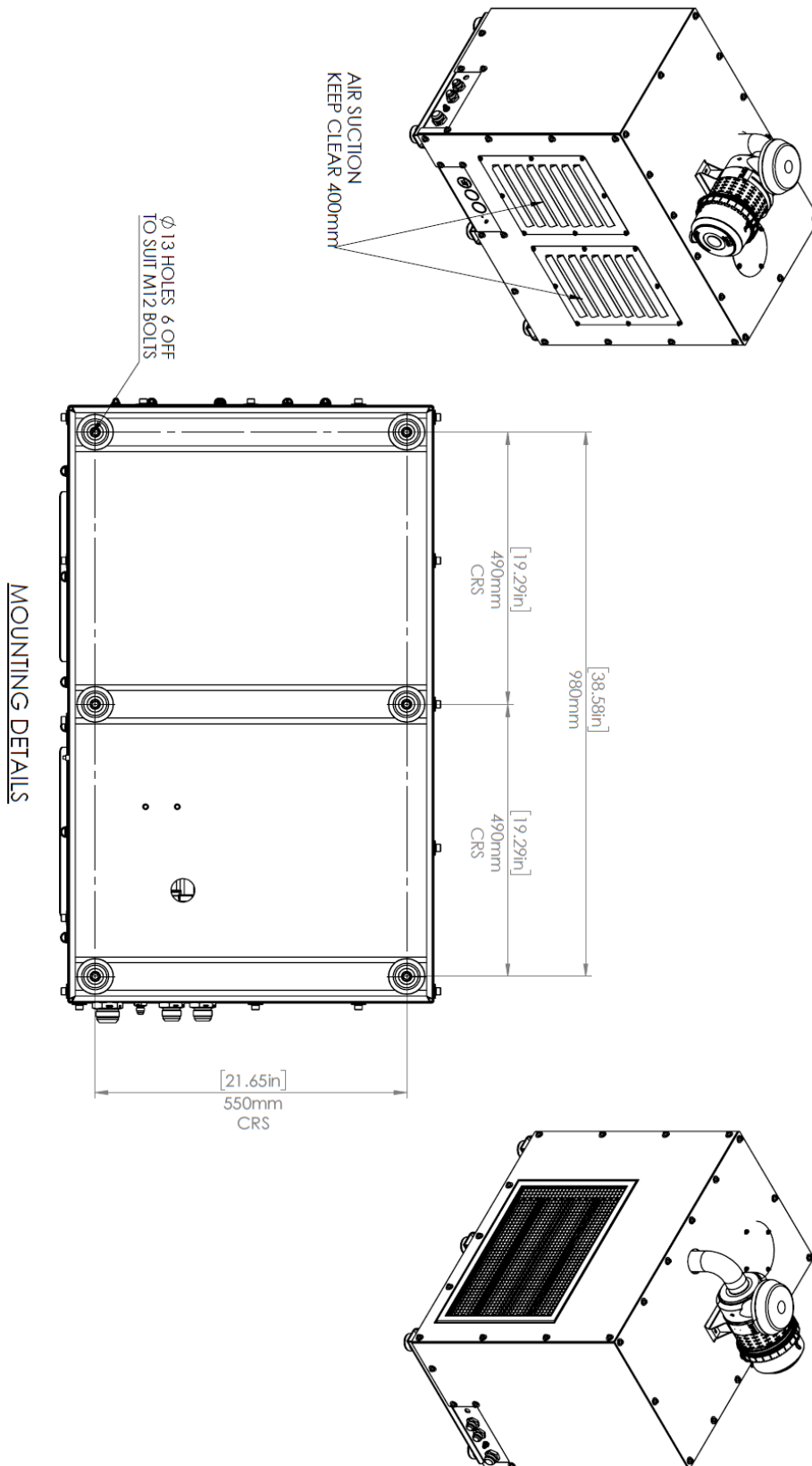

F) SMARTPACK -180H HYDRAULIC CIRCUIT

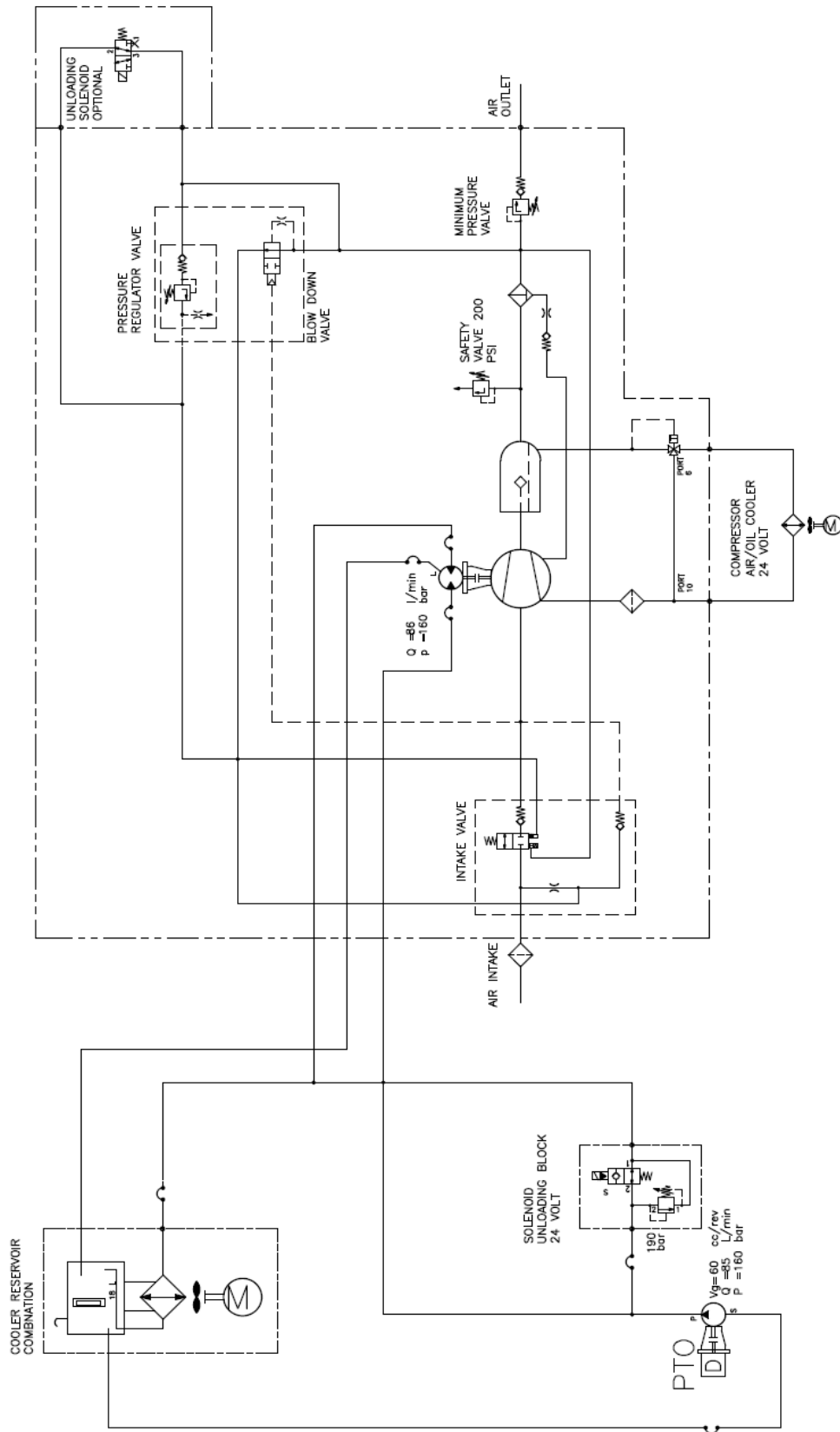

WARRANTY

1 GENERAL PROVISIONS AND LIMITATIONS

- 1.1 Mobile Energy Australia (hereafter "MEA") warrants to each original retail purchaser (hereafter "Buyer") that such product(s) are, at the time of delivery to the buyer, free of manufacture ring defects in material and workmanship.

2 NO WARRANTY IS MADE WITH RESPECT TO

- 2.1 Any product(s) which in the judgment of MEA has been subject to negligence, accident, improper storage, improper installation, improper application, improper operation or maintenance or has been repaired or altered by others without the written authority of MEA..
- 2.2 Components or accessories manufactured, warranted and serviced by others.
- 2.3 Damages caused by the lack of normal maintenance, service and repairs such as the replacement and service of filters and seals.
- 2.4 Damages caused by the lack of normal minimum action, such as adjustments and inspections, replacement of items, such as service filters, seals and service kits.
- 2.5 Consequential damages caused by product(s) failure.
- 2.6 Any product(s) if other than MEA's genuine components are used in the product(s).
- 2.7 Normal wear and tear of product(s).

3 WARRANTY PERIOD

- 3.1 The warranty period will commence upon installation of the product(s). The returned registration form marks the date of installation. If the registration form is not received, the warranty period will be deemed to commence 30 days from date of shipment from MEA.
- 3.2 The Product(s) is warranted against manufacturer defects in materials and workmanship for a period of 12 months.
- 3.3 The compressor air end is warranted to be free from defects in material and workmanship for a period of two (2) years from the date of installation.
- 3.4 Components supplied under warranty shall be warranted for the remainder of the original warranty period.
- 3.5 MEA factory rebuilt components shall be warranted for a period of 6 months from date of shipment.

4 MEA OBLIGATIONS

- 4.1 The obligation of MEA is limited to repairing or replacing parts, during normal business hours, at an authorized service facility, any component, that in the judgment of MEA are defective.
- 4.2 The obligation of MEA is limited to replacement of faulty parts. No liability is accepted for any freight costs, consequential damages, injuries or expenses directly or indirectly related to the Product(s) failure.

WARRANTY (continued)

5 BUYER OBLIGATIONS

- 5.1 Buyer shall notify MEA of the alleged defect within 10 days of initial discovery and return the allegedly defective component(s) within 30 days of initial discovery.
- 5.2 The Buyer must prepay all costs associated with the warranty.
- 5.3 The Buyer must return components claimed under this warranty to a facility designated by MEA for evaluation, to establish a claim under this warranty.
- 5.4 Buyer shall maintain and service MEA Product(s) in accordance with the MEA Product(s) Owner's

6 WARRANTY REGISTRATION VALIDATION

- 6.1 A registration form is provided to the Buyer with the product(s). The form must be fully completed by the Buyer and returned to MEA upon completion of the installation of the product(s) in order to validate the warranty. No warranty claims will be processed unless MEA has received a fully completed warranty registration form.

7 DISCLAIMER AND WARRANTY SERVICE

- 7.1 Any labor costs claimed in excess of MEA's set rate and/or times are not provided by this warranty. If applicable, any labor costs in excess of MEA rate schedules caused by, but not limited to, location or inaccessibility of the equipment, travel time or labor provided by unauthorized service personnel are not provided by this warranty.
- 7.2 This warranty is in lieu of all other warranties or obligations expressed or implied. MEA expressly disclaims all implied warranties of merchantability or fitness for a particular purpose.
- 7.3 Warranty claims must be pre-authorized by MEA, and the components returned via prepaid freight using the designated "Returned Merchandise Authorization" number and form.

PLEASE NOTE:

Both the MEA Product Registration Form and the Kubota Engine Warranty Registration Form MUST be returned to MEA in the stamped, self-addressed envelope.

WARNING!!!

Failure to return PRODUCT WARRANTY REGISTRATION FORMS detailed above may result in the delayed processing of warranty claims.

MOBILE ENERGY AUSTRALIA - CONTACTS

Management

Managing Director – Rob Pulz

Office: 07 3273 6803

Sales

Email: sales@mobileenergyaustralia.com.au

Office: 07 3273 6803

Spare Parts

BH Office: 07 3273 6803

Email: spareparts@mobileenergyaustralia.com.au

Service

Email: workshop@mobileenergyaustralia.com.au

Office: 07 3273 6803