



MEEA
MOBILE ENERGY AUSTRALIA
Specialists in vehicle mounted compressor & generator systems

SMARTPACK 250-H

(7236)

Owner & Operator Manual



SERVICE MAINTENANCE AIR COMPRESSOR – HYDRAULIC DRIVEN

Revision: 1.1
Revised date: 04/04/2019

7235-D0001-01

THIS PAGE WAS LEFT BLANK
INTENTIONALLY.

MEA Product Warranty Registration Form

**THIS FORM MUST BE COMPLETED AND
RETURNED WITHIN 30 DAYS OF INSTALLATION
OR
WARRANTY WILL BE VOID**

CUT HERE



MEA Product Warranty Registration Form

This form must be completed and returned to MEA at the time of Installation. Warranty will be void if this form is not received by MEA within 30 days of installation.

MEA Dealer Information

Company Name: _____

City: _____ State: _____ Country : _____

MEA Installer Information

Company Name: _____

City: _____ State: _____ Country : _____

Installation Date: _____ / _____ / _____
Day Month Year

Owner Information

Company Name: _____

Address: _____

City: _____ State: _____ Country : _____

Postcode: _____ Phone #: _____

Product Information

MEA Serial Number: _____

Model Number: _____

Document No 7235-D0001-01

Table of Contents

1. PRODUCT SAFETY	2
PRODUCT SAFETY -CONTINUED.....	3
2. INTRODUCTION.....	4
3. SPECIFICATIONS	5
4. OPERATING PROCEDURE	6
5. INSTALLATION.....	7
6. SCHEDULE MAINTENANCE	9
7. TROUBLESHOOTING	10
8. SPARE PARTS.....	12
9. DRAWINGS & ILLUSTRATIONS	13
10. WARRANTY	16
11. MOBILE ENERGY AUSTRALIA - CONTACTS.....	19
12. APPENDIX-A COMPRESSOR INFORMATION	20

Both the MEA Product Warranty Registration Form (located at the FRONT of this Manual) is to be returned to MEA.

FAILURE TO RETURN EITHER FORM MAY RESULT IN THE PRODUCT WARRANTY BEING VOID.

1. PRODUCT SAFETY

(COMPRESSOR / COMPRESSED AIR)

MEA DISCLAIMS ALL LIABILITIES FOR DAMAGE OR LOSS OF EQUIPMENT AND PROPERTY, PERSONAL INJURIES (INCLUDING DEATH), AND CONSEQUENTIAL DAMAGES ARISING OUT OF ANY MEA SYSTEM NOT USED IN ACCORDANCE WITH THE OPERATOR'S MANUAL.

ALL UNITS ARE SHIPPED WITH A DETAILED OPERATOR'S MANUAL. THIS MANUAL CONTAINS VITAL INFORMATION FOR THE SAFE USE AND EFFICIENT OPERATION OF THE UNIT. READ THE OPERATOR'S MANUAL BEFORE STARTING THE UNIT. FAILURE TO ADHERE TO THE INSTRUCTIONS COULD RESULT IN SERIOUS BODILY HARM OR PROPERTY DAMAGE.

Care is required when working with an air compressor or compressed air. Compressed air is one of the many ways energy can be stored. Releasing the stored energy in an uncontrolled manner can result in catastrophic consequences. Death and permanent disability are possibilities that can occur due to misuse. The following are suggested as minimum precautions to be used when operating the SMARTPACK Air Compressor. It is important that each work site shall perform a risk analysis and produce a procedure to eliminate or control the hazardous condition to minimise the risk to personnel and equipment. Health and Safety Regulations necessitate that this is a compulsory process to be carried out on each site. These, together with site specific safety procedures will help to minimize the risk to accidents, personnel injury and loss of life. It is the responsibility of the employer to ensure that the work site is safe for all employees and that the safety procedures are followed by all employees.

SAFETY WHEN OPERATING AN AIR COMPRESSOR

- Do not bypass or disable the oil temperature and pressure sensors – unless planning on running to failure (MEA does not recommend the practice).
- Do not expose the tank or compressor to extreme heat.
- Do not perform any service or repairs until the system has been completely relieved of air pressure.
- Maintenance and repairs on the system should only be done by qualified personnel.
- Do not operate the compressor while driving (vehicle mounted systems).
- Do not tamper with the pressure relief valve.
- Follow safe work practice, wear the appropriate personal protective equipment (PPE) when operating air-powered equipment, particularly eye and hearing protection.
- Avoid contact with rotating components, ensure all safety guards are in place.
- Avoid all contact with pressurized air. If it penetrates the skin, it can enter blood stream and cause death.
- Vaporized oil propelled by high pressure is an explosive mixture. To prevent compressor explosion or fire, make sure that the air entering the compressor is free of flammable vapors.
- Do not breathe the compressor air, vaporized oil is a respiratory hazard.
- Stay clear of all moving parts when the system is operating.
- Follow safety procedures for service operations as set by the authority.
- Run the system at idle speed and under no load conditions for 2 to 3 minutes before turning the system off to allow system cooling and lubrication to occur.

HYDRAULIC SAFETY

ALL HYDRAULIC EQUIPMENT MUST BE TREATED WITH EXTREME RESPECT AND CARE. AS THE WORKING FLUID IS UNDER EXTREME PRESSURE, UP TO 5000PSI, WITH HIGH FLOW RATES GENERATING HIGH HEAT, ALL APPROPRIATE SAFETY PRECAUTIONS MUST BE TAKEN IN TO ACCOUNT AND SAFETY EQUIPMENT MUST BE WORN IF IN CONTACT WITH THE EQUIPMENT UNDER OPERATION. ALL LEAKS, NO MATTER HOW MINOR, MUST BE RECTIFIED IMMEDIATELY AND ANY WEAR IN THE HOSES MUST BE ADDRESSED AND EQUIPMENT REPLACED. HYDRAULIC INJECTION IS DANGEROUS AND LIFE THREATENING AND EVEN A PINHOLE LEAK WILL BLANKET AN ENTIRE ENCLOSED SPACE VERY QUICKLY WITH HAZERDOUS VAPORISED HYDRAULIC OIL MIST.

2. INTRODUCTION

This MEA vehicle mounted air compressor system utilizes the available hydraulic power for the running of the installed compressor to supply compressed air at the specified flow rate and pressure.

Only those who have been properly trained and delegated to do so, and who have read and understand the operation and installation procedures should install MEA compressor systems.

This Manual contains vital information of the compressor system and its integration into the existing hydraulic system to ensure that it is operated in a safe and efficient manner.

The air is drawn via the intake filter, and then through the intake valve into the compression Chamber. In the compression chamber, the air is compressed, and oil is injected for lubrication and cooling. The oil-air mixture then enters the separating tank in which most of the oil is separated from the air. The air travels to the compressed air outlet via the air-oil separating element and the minimum pressure valve and ready to be utilized.

In the air-oil separating element, the oil is filtered out down to a residual content of < 3 mg/m³ and is then conveyed back into the compressor housing via a nozzle and the non-return valve.

When the compressor module is switched off, the minimum pressure valve with a non-return function prevents backflow of the compressed air out of the system into the compression chamber.

During start up a faster pressure build-up is also ensured, which is required for optimum lubrication and oil separation.

The heat resulting during compression is dissipated via the oil-air mixture. The oil circulation also results from the pressure difference between the outlet and inlet pressure. The optimum operating temperature for the oil is adjusted by the integrated oil thermostat. Depending on the oil temperature, the oil thermostat valve routes the oil flow via the oil cooler or directly to the oil filter. The oil then flows via the oil filter to the various injection points in the compressor block.

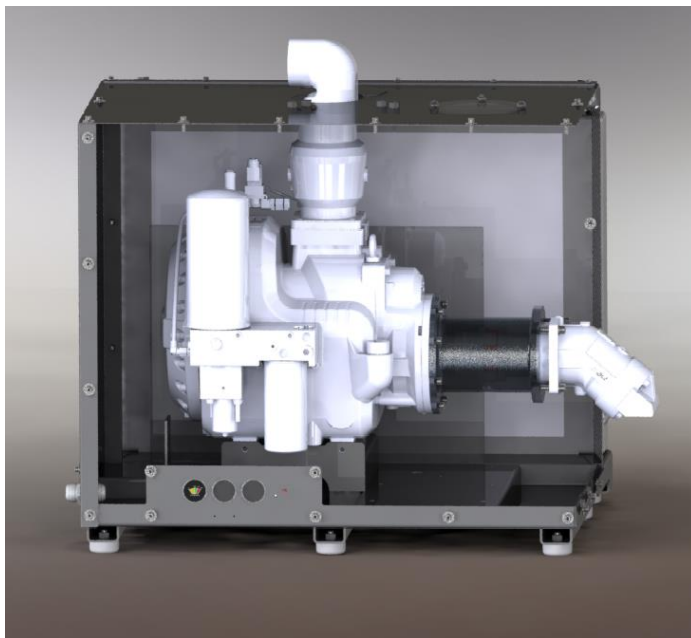

3. SPECIFICATIONS

Compressor Model: EVO9-NK

Compressor Type: Oil injected screw compressor

Hydraulic Motor Type: 84cc Bent-Axis Piston Motor

Control: 24V/12V Electronic Control, optional unloading valve for hydraulic flow control

Maximum Air Delivery: 250cfm @ 116psi

Oil Flow Requirements: 181 LPM

Oil Pressure (Nominal): 195 Bar

Drive coupling speed: 2160 rpm

Pressure Regulation: Mechanical Inlet control valve modulates flow in response to demand

Safety Features: 200 PSI relief valve in compressor sump
Temperature safety sensor in compressor
Rapid blow-down valve to discharge system pressure on shutdown

Lubrication: MEA Certified and Approved Synthetic Oil for compressor.

Filters: Two-stage Air Filter, Spin-on type oil filter, Coalescing separator element

4. OPERATING PROCEDURE

WARNING

CAREFULLY READ THE OPERATING INSTRUCTIONS BELOW. FAILURE TO ADHERE TO THE FOLLOWING COMPRESSOR OPERATING INSTRUCTION COULD RESULT IN SERIOUS INJURY.

1. Check Oil Level (Refer to Page 15).
2. Check Hoses and fittings for leaks. Make sure the hoses are not loosened nor damaged.
3. Check and make sure hydraulic supply/return/drain are installed correctly (Refer to Page 7).
4. Check Air Filter for Blockage.
5. Check the Safety circuit switch operation (Reset Switch).
6. Switch on the vehicle and activate the vehicle flow control (turn PTO on; for vehicle mounted system). In other systems, start the hydraulic system by starting the hydraulic pump.
7. Turn on the compressor either at the control box (or in the cab) and ensure it is in the unloaded state (check load/unload switch).
8. Turn on the unload/load switch to load and see if the compressor builds pressure to the regulated setting.
9. Plug an air tool into the air outlet and operate. Ensure that the compressor works as required.
10. When the work is finished, switch the compressor to unload.
11. Switch off at either the control box or in Cab and switch off the vehicle.
12. It is good practice to check for any visible signs of hydraulic fluid leakage and or compressor fluid leakage after each use.

5. INSTALLATION

The SMARTPACK 250H is designed as an integrated compressor system for connection to an existing hydraulic system. The SMARTPACK 250H only requires connection of a pressure line in, a return line out and a connection of the motor drain line to the existing hydraulic system (tank).

For any air flow requirements, a table is given (Page 8) as a reference to set up the compressor hydraulic oil flow required on the hydraulic pump.

WARNING(!) When setting the compressor unit up, ensure there is a safety mechanism in place to prevent any excessive flow or pressure into the compressor hydraulic circuit. MEA will not warrant any damage caused and will void warranty due to inadequate safety protection of the existing hydraulic system.

1. Install SMARTPACK 250H into position on the vehicle, using 8 x M12 x 1.75 Grade 8.8 Fasteners.
2. Install the hydraulic lines (**i.e. pressure in, return out and drain lines**).

HOSE	PORT
PRESSURE LINE	A
RETURN LINE	B
DRAIN LINE	DRAIN

For units with unloader valve, inlet and outlet ports are marked and easily identifiable on the valve body.

3. In installing a frameless version; install the cooler in place and connect the compressor cooler lines between the cooler and the compressor.
4. Connect the electrical control box to the vehicle; be sure to place an in-line weatherproof fuse (30A – 12V and 20A – 24V) within 300mm of the vehicle battery. Ensure the control box is compatible with your vehicles voltage rating.
5. Connect the terminals of the electrical loom as per the electrical harness diagram (Page 16).
6. Check the oil level in the compressor (Page 15).
7. Switch on the vehicle (or switch on the hydraulic system if its standalone), turn on the compressor at the control box and test the hydraulic solenoid for operation.
8. Turn the unload/load switch to load and check the compressor builds pressure to the regulated pressure setting.
9. Plug an air tool into the air outlet and operate checking that the compressor works as required, run for 10mins.
10. Unload the compressor, switch off the control box, switch off the vehicle and check for any visible signs of hydraulic fluid leakage.
11. When the compressor has cooled down (safe to touch), re-check the compressor oil level.

Hydraulic/Air Flow-Pressure Calculation

SMARTPACK 250-H

Motor Displacement CC/Rev 84 Gear Ratio 1: 2.43
Nominal Operating Pressure 197 Bar

CFM	HYD MOTOR RPM	M ³ /MIN	LOBE SPEED	KW@116 PSI	HP @116 PSI	OIL FLOW LPM
160	1409	4.53	3424	35.1	47.1	132
170	1492	4.81	3626	37.2	49.9	139
180	1576	5.10	3830	39.3	52.7	147
190	1659	5.38	4031	41.3	55.4	155
200	1742	5.66	4233	43.4	58.2	163
210	1825	5.95	4435	45.5	61.0	170
220	1908	6.23	4636	47.6	63.8	178
230	1991	6.51	4838	49.6	66.5	186
240	2075	6.80	5042	51.7	69.4	194
250	2158	7.08	5244	53.8	72.1	201
260	2241	7.36	5446	55.9	74.9	209

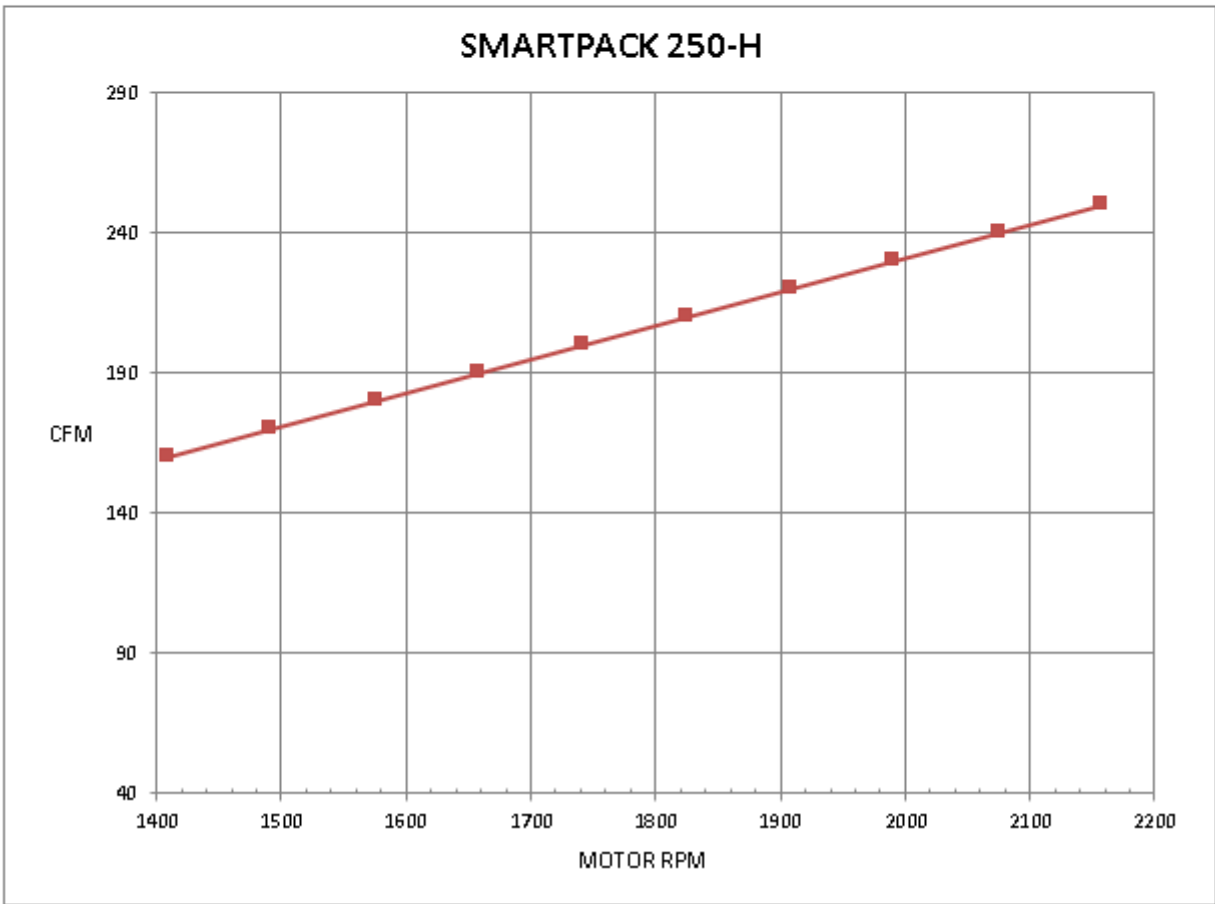

6. SCHEDULE MAINTENANCE

Maintenance schedules are given as per components' manufacturer standards under normal operating. If the operating conditions deviate from standard (such as severe environmental conditions), it is necessary to take steps for the affected areas to be maintained at shorter intervals.

For details on maintenance procedures, consult "Compressor Information (APPENDIX-A)".

Before first start	Check the oil level in the separating tank
Periodically	Observe all gauge readings. Note any change from the normal readings and determine the cause. Have the necessary repairs made.
	(Note: "Normal" is the usual gauge reading when operating at similar conditions on a day to day basis.)
Periodically or as required	Inspect and clean oil cooler fins.
	Check system for oil and/or air leaks.
	Inspect and replace spin-on coalescing element if necessary
Once after 50 operating hours	Check the oil level in the separating tank
	Tighten all screw pipe fittings and electrical screw terminal fittings.
	Check all other connections for firm seating
Every 100 hours	System Inspection:
	(1) Check oil level in separating tank, top up if oil is low
	(2) Check maintenance indicator (if applicable)
	(3) Listen for abnormal running noise during operation
	(4) Check all lines, hoses, and screw fittings for leaks and externally visible damage
Every 1,000 Hours depending on application Recommendation: at least every 12 months (if operated in dusty environment, shorter frequency or as required)	Changing the air-oil separating element
	Carry out oil change
	Replace oil filter
	Replace filter element in intake air filter
	Check system for leaks
	Clean the system
Every 2 years with increased demand (multi-shift operation, mobile unit)	Replace hose (if attached to the compressor module)
Every 6 years with normal demand	Replace hose (if attached to the compressor module)

7. TROUBLESHOOTING

(Detailed procedures on troubleshooting of the compressor system can be found in “Compressor Information (APPENDIX-A)”.

Fault	Possible cause	Remedy
Not functioning	Control box or electrical connection faulty	Have control box or electrical connection repaired. Incorrect rotation direction Phases reversed Reconnect
Incorrect rotation direction	Hoses are connected wrongly	Reconnect supply and return hoses
Screw compressor system has difficulty starting	Flow and pressure not insufficient	Inspect
	Drive transmission ratio too fast	Check flow and pressure
	Star-delta switchover incorrect	Set
	Compressor is flooded with oil	Check
	System has not been depressurized yet	Check, depressurize if necessary
	Ambient temperature too low Oil filling too viscous	Check viscosity of the oil Check viscosity of the oil
Pressure losses at filter cartridges	Excessive pressure loss at air-oil separating element	Replace air-oil separating element
Combistat switches off due to excessively high temperature	Oil shortage	Check the oil level in the oil reservoir, fill if necessary
	Oil filter soiled	Replace oil filter cartridge
	Oil thermostat faulty	Replace oil thermostat
	Oil cooler soiled	Clean oil cooler on air side, clean on oil side if necessary
	Incorrect setup a) Room ventilation b) Exhaust air obstructed c) Thermal short-circuit	Follow recommendations for installation of the compressor system
	Combistat defective	Replace combistat
Safety valve blows off (at a permissible operating pressure)	Safety valve defective	Replace safety valve
	Air-oil separating element dirty	Replace air-oil separating element
	Compressor system does not switch off automatically, control valve operates intermittently	Check the solenoid valve, replace if necessary
Oil in compressed air	Operating pressure and delivery quantity is not in the permissible range	Check pressures
	Oil exhaust system contaminated	Clean oil extraction system
	Air-oil separating element faulty	Check air-oil separating element and replace if necessary
	Oil level in oil reservoir too high; possibly excessive condensate	Observe oil level marking; drain and replace if necessary
Compressor system is not discharged during continuous operation,	Upper switching point of network pressure monitor set too high	Readjust network pressure monitor

system does not switch off automatically in case of intermittent operation, i.e. safety valve blows off	Solenoid valve defective Relief valve defective	Replace solenoid valve/ relief valve
	Minimum pressure valve jams	Check minimum pressure valve for smooth movement; if necessary, ensure smooth movement or replace
Compressor system continually discharges, low delivery quantity	Solenoid valve defective	Replace solenoid valve
	Break in electric supply line to solenoid valve	Eliminate break
No or insufficient feed quantity	Intake filter soiled	Replace filter insert
	Oil shortage	Check oil level, top up if necessary
	Intake control valve jams or is incorrectly positioned	Check control valve and control valve flap, clean bearing and guides, check stroke, replace if necessary
	Leaks in system	Check seal
Control valve does not open	Compressor system leaky	Check system and seal off if necessary
	Solenoid valve/electrical system, bypass valve, piston gasket, and minimum pressure valve not functioning	Check and replace parts
Control valve does not control (two-point/step-less)	Pressure switch in system is set incorrectly	Check setting, adjust and replace if necessary
Oil escapes during stop	Sealing surfaces in control valve damaged, spring in control valve broken	Check and replace parts
Compressor system does not discharge (discharge time 100 - 200 seconds, depending on separator size)	Solenoid valve/electrical system not functioning	Check and replace parts
Control valve constantly discharges	Solenoid valve/electrical system not functioning	Check and replace parts
Oil escapes during discharging (oil foam in air-oil separating element)	Oil type incorrect	Change oil
	Oil foam forms during stop	Check and replace discharge delay valve, with a different nozzle diameter if necessary
	Oil level too high	Drain off oil
Abnormal noise during operation	Insufficient lubrication, loose parts, damage to drive, transmission, bearings, or shaft, etc.	Check, if necessary, replace parts or have them replaced

8. SPARE PARTS

Part Number	Description
10008-P0089	Air Filter Assembly
10008-P0161	AIR Filter Element - Primary Filter
10008-P0162	AIR Filter Element - Safety Filter
10008-P0087	Air-Oil Separator Element
10008-P0163	Oil Filter
10012-P0083	Unloader Valve 12V
10012-P0084	Unloader Valve 24V
10022-P0064	Shaft Seal Kit
20012-P0004	Relay 12V
20012-P0005	Relay 24V
10004-P0168	Coupling Hub (Motor)
10004-P0169	Coupling Hub (Compressor)
10004-P0170	Spider for Coupling

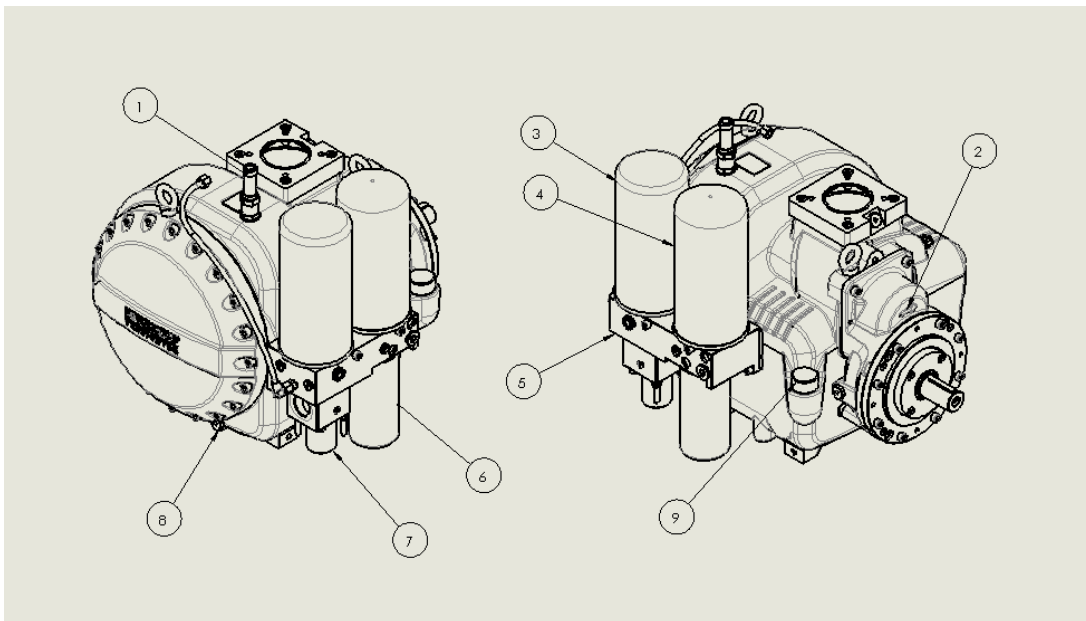

1. Safety Valve
2. Pre-set direction (clockwise rotation)
3. Air-Oil seperating element A
4. Air-Oil seperating element B
5. Multiblock
6. Oil filter
7. Minimum pressure valve
8. Oil drain plug
9. Oil filler opening

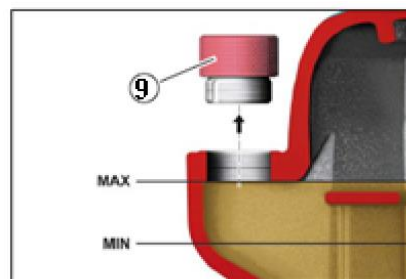

Oil level check via oil filler opening
(sample depiction)

5. Multiblock

1. Air-oil separating element
2. Oil circulation connection/inlet
3. Oil circulation connection/outlet
4. Oil return line check
5. Housing
6. Oil thermostat
7. Oil separation return line (integrated non-return valve)
8. Minimum pressure valve
9. Oil filter

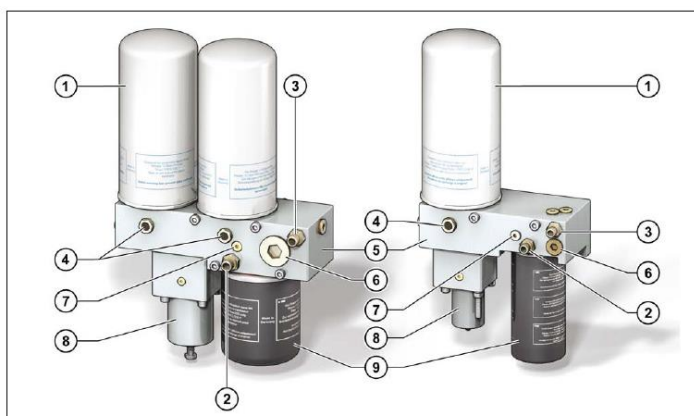

SMARTPACK-250H HYDRAULIC CIRCUIT

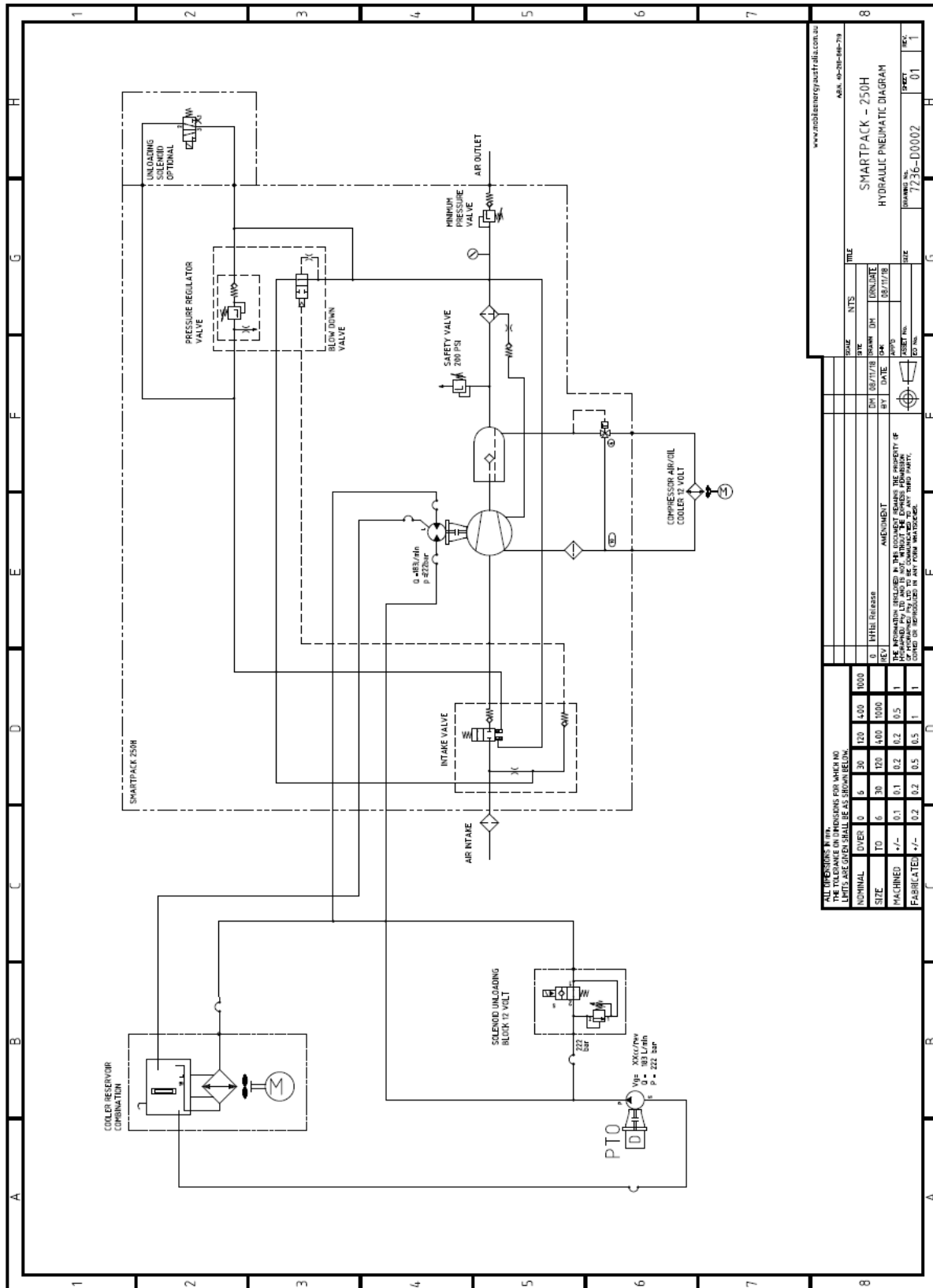

10. WARRANTY

1 GENERAL PROVISIONS AND LIMITATIONS

- 1.1 Mobile Energy Australia (hereafter “MEA”) warrants to each original retail purchaser (hereafter “Buyer”) that such product(s) are, at the time of delivery to the buyer, free of manufacture ring defects in material and workmanship.

2 NO WARRANTY IS MADE WITH RESPECT TO

- 2.1 Any product(s) which in the judgment of MEA has been subject to negligence, accident , improper storage, improper installation, improper application, improper operation or maintenance or has been repaired or altered by others without the written authority of MEA..
- 2.2 Components or accessories manufactured, warranted and serviced by others.
- 2.3 Damages caused by the lack of normal maintenance, service and repairs such as the replacement and service of filters and seals.
- 2.4 Damages caused by the lack of normal minimum action, such as adjustments and inspections, replacement of items, such as service filters, seals and service kits.
- 2.5 Consequential damages caused by product(s) failure.
- 2.6 Any product(s) if other than MEA’s genuine components are used in the product(s).
- 2.7 Normal wear and tear of product(s).

3 WARRANTY PERIOD

- 3.1 The warranty period will commence upon installation of the product(s). The returned registration form marks the date of installation. If the registration form is not received, the warranty period will be deemed to commence 30 days from date of shipment from MEA.
- 3.2 The Product(s) is warranted against manufacturer defects in materials and workmanship for a period of 12 months.
- 3.3 The compressor air end is warranted to be free from defects in material and workmanship for a period of two (2) years from the date of installation.
- 3.4 Components supplied under warranty shall be warranted for the remainder of the original warranty period.
- 3.5 MEA factory rebuilt components shall be warranted for a period of 6 months from date of shipment.

4 MEA OBLIGATIONS

- 4.1 The obligation of MEA is limited to repairing or replacing parts, during normal business hours, at an authorized service facility, any component, that in the judgment of MEA are defective.
- 4.2 The obligation of MEA is limited to replacement of faulty parts. No liability is accepted for any freight costs, consequential damages, injuries or expenses directly or indirectly related to the Product(s) failure.

WARRANTY (continued)

5 BUYER OBLIGATIONS

- 5.1 Buyer shall notify MEA of the alleged defect within 10 days of initial discovery and return the allegedly defective component(s) within 30 days of initial discovery.
- 5.2 The Buyer must prepay all costs associated with the warranty.
- 5.3 The Buyer must return components claimed under this warranty to a facility designated by MEA for evaluation, to establish a claim under this warranty.
- 5.4 Buyer shall maintain and service MEA Product(s) in accordance with the MEA Product(s) Owner's

6 WARRANTY REGISTRATION VALIDATION

- 6.1 A registration form is provided to the Buyer with the product(s). The form must be fully completed by the Buyer and returned to MEA upon completion of the installation of the product(s) in order to validate the warranty. No warranty claims will be processed unless MEA has received a fully completed warranty registration form.

7 DISCLAIMER AND WARRANTY SERVICE

- 7.1 Any labor costs claimed in excess of MEA's set rate and/or times are not provided by this warranty. If applicable, any labor costs in excess of MEA rate schedules caused by, but not limited to, location or inaccessibility of the equipment, travel time or labor provided by unauthorized service personnel are not provided by this warranty.
- 7.2 This warranty is in lieu of all other warranties or obligations expressed or implied. MEA expressly disclaims all implied warranties of merchantability or fitness for a particular purpose.
- 7.3 Warranty claims must be pre-authorized by MEA, and the components returned via prepaid freight using the designated "Returned Merchandise Authorization" number and form.

PLEASE NOTE:

Both the MEA Product Registration Form and the Kubota Engine Warranty Registration Form MUST be returned to MEA in the stamped, self-addressed envelope.

WARNING!!!

Failure to return PRODUCT WARRANTY REGISTRATION FORMS detailed above may result in the delayed processing of warranty claims.

11. MOBILE ENERGY AUSTRALIA - CONTACTS

Sales

Email: sales@mobileenergyaustralia.com.au

Office: 07 3273 6803

Spare Parts

BH Office: 07 3273 6803

Email: sales@mobileenergyaustralia.com.au

Service

Email: workshop@mobileenergyaustralia.com.au

Office: 07 3273 6803

12. APPENDIX-A COMPRESSOR INFORMATION

Installation and operating manual

**COMPACT MODULE SCREW COMPRESSOR
EVO1-NK, EVO2-NK, EVO3-NK/EVO3-NK-G,
EVO6-NK/EVO6-NK-G, EVO9-NK/EVO9-NK-G**



Installation and operating manual – EVO-NK

1	Foreword	1-1	4	Transport	4-1
1.1	General	1-1	4.1	Delivery and packing	4-1
1.2	Scope	1-1	4.2	Transport damage	4-1
1.3	Change service	1-1	4.3	Transporting unpacked system	4-2
1.4	Abbreviations	1-1	4.4	Transport options.....	4-2
1.5	Manufacturer's information.....	1-1	5	Installation and assembly, disassembly, storage	5-1
1.5.1	General information.....	1-1	5.1	Connection thread/assembly	5-1
1.5.2	Intended use	1-2	5.1.1	Fastening screws.....	5-1
1.5.3	Improper use	1-2	5.1.2	Pipe connections	5-1
1.5.4	Standard delivery scope.....	1-2	5.1.3	Piping materials	5-1
1.6	Warranty information, liability disclaimer	1-2	5.2	Safety precautions for installation and assembly	5-2
1.7	Nameplate.....	1-3	5.3	Installation	5-2
2	Safety precautions	2-1	5.3.1	Fastening to base frame with screw fitting.....	5-3
2.1	Identification of safety instructions	2-1	5.4	Drive	5-3
2.2	Safety regulations	2-1	5.4.1	Belt drive.....	5-3
2.3	General safety instructions	2-1	5.4.2	Direct drive	5-4
2.3.1	Safety symbols.....	2-2	5.5	Air outlet	5-4
2.3.2	Disposal	2-2	5.6	Oil cooling.....	5-5
3	Technical Description	3-1	5.7	Disassembly/decommissioning	5-5
3.1	General overview of the EVO-NK compact module screw compressor	3-1	5.8	Storage	5-6
3.1.1	EVO1-NK compact module	3-1	6	Commissioning	6-1
3.1.2	EVO2-NK compact module	3-2	6.1	Preparation for commissioning	6-1
3.1.3	EVO3-NK compact module	3-3	6.2	Checking rotation direction	6-1
3.1.4	EVO6-NK compact module	3-5	6.3	Test run	6-2
3.1.5	EVO9-NK compact module	3-7	6.4	Resuming operation of the screw compressor system	6-2
3.2	Specifics by transmission version	3-9	7	Maintenance and repair	7-1
3.3	Operating description for the EVO-NK compact module screw compressor.....	3-10	7.1	Safety precautions.....	7-1
3.3.1	EVO-NK flow diagram	3-10	7.2	Maintenance and spare parts	7-1
3.3.2	Operating description	3-11	7.3	Cleaning	7-2
3.4	Intake valve	3-12	7.4	Oil level	7-2
3.4.1	Installation position.....	3-13	7.4.1	Oil level check via oil filler opening.....	7-2
3.5	Intake air filter	3-13	7.4.2	Oil level check via sight glass (optional).....	7-3
3.5.1	Intake filter monitoring.....	3-13	7.5	Oil change	7-3
3.6	Multiblock	3-14	7.5.1	Oil change intervals	7-4
3.7	Oil intake non-return valve	3-15	7.5.2	Oil drain point	7-4
3.8	Air-oil separating element	3-15	7.5.3	Filling with oil	7-4
3.8.1	Minimum pressure valve	3-17	7.6	Oil filter	7-5
3.9	Oil filter	3-18	7.6.1	Oil filter replacement intervals	7-5
3.10	Oil thermostat.....	3-18	7.6.2	Replace oil filter	7-5
3.11	Oil cooler/air cooler (optional)	3-19	7.7	Air-oil separating element.....	7-6
3.12	Safety valve (SV) (optional)	3-19	7.7.1	Maintenance intervals.....	7-6
3.13	Air-oil circulation outside the compressor module	3-21	7.7.2	Changing the air-oil separating element.....	7-6

Installation and operating manual - EVO-NK

7.8	Intake air filter	7-7
7.8.1	Maintenance intervals	7-7
7.8.2	Replacing air filter element.....	7-7
7.9	Maintenance check sheet (template).....	7-8
7.10	Maintenance intervals.....	7-9
8	Lubricants and operating materials	8-1
8.1	Oil recommendation.....	8-1
8.1.1	Multigrade oil.....	8-1
8.2	Topping off oil	8-1
8.3	Measures at low room temperature	8-1
8.4	Pressure dew point of compressed air	8-2
8.5	Temperatures	8-2
8.6	Condensation damage.....	8-2
8.7	Cold starts.....	8-3
8.8	Oil separation.....	8-3
9	Technical Data and Tightening Torques	9-1
9.1	EVO1-NK technical data.....	9-1
9.2	EVO2-NK technical data.....	9-2
9.3	EVO3-NK technical data.....	9-3
9.4	EVO6-NK technical data.....	9-4
9.5	EVO9-NK technical data.....	9-5
9.6	Tightening torques	9-6
10	Troubleshooting	10-1

Installation and operating manual – EVO-NK

1 Foreword

1.1 General

This installation and operating manual contains notes and rules for transport, installation, commissioning, operation, maintenance, repair, disassembly, and storage of compact module screw compressors

- EVO1-NK,
- EVO2-NK,
- EVO3-NK/EVO3-NK-G,
- EVO6-NK/EVO6-NK-G and
- EVO9-NK/EVO9-NK-G.

1.2 Scope

This installation and operating manual applies to screw compressors of the EVO-NK compact module type after the delivery date 04/2012.

1.3 Change service

This document is not subject to the change service.

1.4 Abbreviations

bar (g)	Operating gauge pressure (relative pressure in bar)
OH	Operating hours
BSP	British standard pipe thread (Whitworth pipe thread)
MPV	Minimum pressure-retaining valve
EVV	Discharge delay valve
G	Transmission
Max.	maximum
Min.	minimum
psi (g)	Operating gauge pressure (relative pressure in pound force/in ²)
RC	ROTORCOMP VERDICHTER GmbH
SV	Safety valve
V AC	Alternating voltage
V DC	Direct voltage

1.5 Manufacturer's information

1.5.1 General information

This installation and operating manual provides information about functions, installation, operation, and maintenance of the EVO-NK. Consulting it is therefore an absolute requirement for operation and maintenance of the EVO-NK.

Please read this installation and operating manual carefully before the first commissioning of the EVO-NK in order to ensure proper handling, operation, and maintenance.

It is absolutely mandatory to follow all safety instructions contained in this installation and operating manual.

ROTORCOMP compact module screw compressors are carefully checked and tested prior to shipping. When your compressor arrives, the delivery scope must be checked for completeness and damage.

Any missing parts and/or transport damage must be reported immediately. A damaged compressor module must not be placed into service under any circumstances.

Always keep the installation and operating manual available for the operating personnel and make sure that operation and maintenance are carried out according to the instructions.

All instructions contained in this installation and operating manual must be observed in the specified manner and sequence in order to prevent injuries to personnel and damage to the screw compressor system.

The compressor module has been built according to the latest technology and the recognized safety rules.

During their use, however, there is still the risk of injury to users or third parties or damage to the compressor system.

Any other use than described in the chapter 1.5.2 "Intended use" constitutes improper use.

ROTORCOMP VERDICHTER GmbH is not liable for damage resulting from such improper use.

We cannot honor warranty claims for operating malfunctions and damage arising from failure to comply with instructions given in this installation and operating manual.

The manufacturer reserves the right to carry out further technical developments without prior notice.

Always specify the model and the complete serial number from the nameplate in all correspondence.

ROTORCOMP VERDICHTER GmbH assumes no liability whatsoever for damage or injuries which occur during handling, operation, maintenance work, or repairs due to failure to comply with the safety instructions or failure to exercise the customary care and caution, even if this is not expressly mentioned in this installation and operating manual.

1.5.2 Intended use

The compact module screw compressor EVO-NK is only used to compress atmospheric air.

Use of the compressor module for compressing gases and other media is only permissible with written approval from ROTORCOMP VERDICHTER GmbH.

The compressor module starting from the EVO3-NK size are available both with and without a transmission (G).

The compressor module is designed for installation in a compressed air generating station (compressor system).



Warning:

If the compressor module is not used in accordance with these regulations, there is no guarantee of safe operation!

1.5.3 Improper use

Under no circumstances is the compact module screw compressor EVO-NK to be

- installed in machines other than the screw compressor system.
- installed in explosive environment.
- operated outside the given limit values.
- used to compress gases other than those listed in chapter 1.5.2 "Intended use".
- used with unsuitable operating materials (gases, oils).
- used to compress toxic, corrosive, explosive, or noxious gases.
- to compress or transport fluids, powders, or solids.

If you have questions, please contact ROTORCOMP VERDICHTER GmbH.

1.5.4 Standard delivery scope

With the EVO-NK, ROTORCOMP VERDICHTER GmbH offers a completely equipped, compact module screw compressor.

The components of the standard delivery scope are described in the following chapters. Optionally available components are marked with "Option".

1.6 Warranty information, liability disclaimer

ROTORCOMP VERDICHTER GmbH is a manufacturer of screw compressor components and not of ready-to-operate compressor systems.

RC shall only be answerable for any defects of these individual components for which it is responsible within the scope of the warranty conditions.

Failure to comply with the following instructions and information shall void any and all liability. This liability disclaimer also results in the loss of claims for damages. This applies in particular in case of:

- Unprofessional installation.
- Improper use.
- Operation of the compact module screw compressor outside the specified limits (see chapter 9 "Technical Data and Tightening Torques").
- Failure to observe the safety precautions and the usual care and caution.
- Unsuitable operating materials (gases, oils).
- Formation of condensation in the compressor module.
- Corrosion as subsequent damage.
- Improper operation.
- Insufficient maintenance, missing proof of maintenance.
- Use of unsuitable tools.
- Failure to use genuine spare parts.
- Unauthorized modifications to the compressor module and/or its components.

Installation and operating manual – EVO-NK

1.7 Nameplate

Installing the nameplate, see Figures 3-1 through 3-8.

If you have questions, please provide us with the data on the nameplate. This will ensure that you receive the correct information.

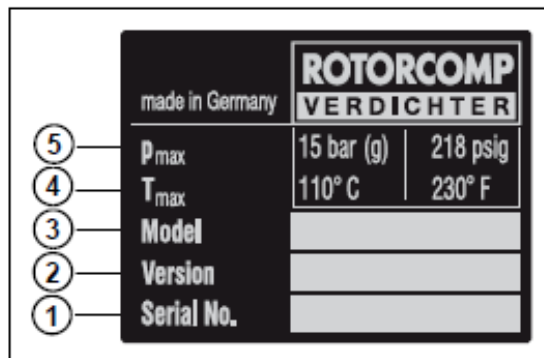

Figure 1-1 Nameplate (example)

1. Serial No.
2. Version
3. Model
4. Max. operating temperature in 110 °C/230 °F
5. Max. operating pressure in (g)/psi (g)



Note:

The transmission ratio (numbers of teeth) is stamped on the transmission (see Figs. 3-4, 3-6 and 3-8).

Alternatively, a customer-specific nameplate can be mounted on the compact module screw compressor.

2 Safety precautions

2.1 Identification of safety instructions

Important instructions concerning hazards to persons, technical safety and their operational safety are especially highlighted in the following. They precede the measures to be taken and have the following meanings:



Warning:

Indicates working and operating processes which must be exactly complied with in order to prevent endangering of persons. These also include instructions about particular dangers inherent in the use of the screw compressor system.



Attention:

Refers to working and operating processes which must be exactly complied with to prevent damage to or destruction of parts of the compact module screw compressor or the entire compressor system.



Note:

Indicates special information for better handling during operation, inspection, and adjustment processes and care work.

2.2 Safety regulations

The regulations of the respective country for placement into service and operation of screw compressor systems must be observed. In Germany these include:

- Directive 2006/42/EC (Machinery directive MRL)
- Directive 97/23/EC (Pressure equipment directive DGRL)
- Ordinance on Industrial Safety and Health (BetrSichV).

2.3 General safety instructions

This installation and operating manual contains important instructions and information on the transport, installation, commissioning, operation, maintenance, repair, disassembly, and storage that must be adhered to by the manufacturer and by the owner of the screw compressor system.

As a result, it is absolutely mandatory to turn over the entire documentation to the specially trained personnel of the operator and to make it available at the operating location prior to installation and commissioning.

Prior to installation, commissioning, operation, maintenance, and repair, the specially trained personnel must carefully read the entire installation and operating manual and then keep it in a safe place.

Failure to follow safety instructions can result in a serious hazard for the personnel, the pressure vessel or the environment.

Pay close attention to chapter 1.5 "Manufacturer's information" in this installation and operating manual.

The following safety instructions relate only to the compact module screw compressor EVO-NK and not to the entire screw compressor system.

It is mandatory to comply with the applicable national safety and occupational safety regulations of the respective country in which the compressor system is operated.

The manufacturer of the compressor system is responsible for including the necessary safety regulations for the operation of the in the instruction manual of the system.

The owner bears the responsibility for always keeping the machine in safe operating condition. Limits (pressures, temperatures, time settings, etc.) must be permanently marked.

Should a regulation contained in this list, especially with regard to safety, not conform to legal regulations, then the safer of the two applies.

It is critical to be aware of and adhere to the safety instructions, technical data, limit values, installation guidelines, and instructions for transport, installation, commissioning, operation, maintenance, repair, disassembly, and storage given in this installation and operating manual.

Installation and operating manual - EVO-NK

Do not carry out any modifications or rebuilding of the compressor module: modifications not authorized by ROTORCOMP VERDICHTER GmbH render the CE manufacturer's declaration invalid!

Observe the local safety regulations!

Installation, commissioning, operation, maintenance, repair, and disassembly must be carried out only by authorized, trained, and qualified personnel.

The operating personnel are expected to safely use the working technology and to comply with all applicable local operating safety rules and regulations.

Close-fitting clothing and the necessary personal safety equipment must be used during transport, installation, maintenance, repair, and disassembly of the compressor module.

Work on the electrical equipment must only be performed by a qualified electrician. Unqualified persons must be prohibited from performing work on electrical equipment!

The following apply to all installation, assembly, commissioning, maintenance, repair, and disassembly work:

- Ensure sufficient illumination of the compressor module.
- Ensure sufficient tread safety in the region of the compressor module.

Risk of injury from rotating and pressurized components.

Risk of burns due to unit parts or oil hotter than 80 °C. Allow the screw compressor system to cool.

Only use permissible or suitable tools for installation, assembly, maintenance, and repair work.

Do not perform welding work or any other work that requires or produces heat near the oil system.

Only use the operating materials described above! When handling oils, greases, and other chemical substances, comply with the safety regulations that are applicable for the product!

Make absolutely sure that no lubricants or oil escape into the ground, the sewer system, or bodies of water.

During assembly, maintenance, and repair, make sure to keep everything absolutely clean. Keep dirt away from the system. Cover parts and exposed openings with a clean cloth, paper or strips of adhesive tape.

2.3.1 Safety symbols



Warning:

Safety symbols and signs that are required for transport, installation, commissioning, operation, maintenance, and repair must be permanently attached to the screw compressor system by the manufacturer of the screw compressor system. They must always be kept in a legible condition and replaced if necessary.

2.3.2 Disposal



Attention:

All parts of the compact module screw compressor must be disposed of and/or recycled in accordance with the applicable laws.

Oil filter cartridges, air-oil separating elements, lubricant residues, used oil, and other materials contaminated with oil must be collected and disposed of in accordance with the applicable regulations.

Installation and operating manual – EVO-NK

3 Technical Description

3.1 General overview of the EVO-NK compact module screw compressor

3.1.1 EVO1-NK compact module

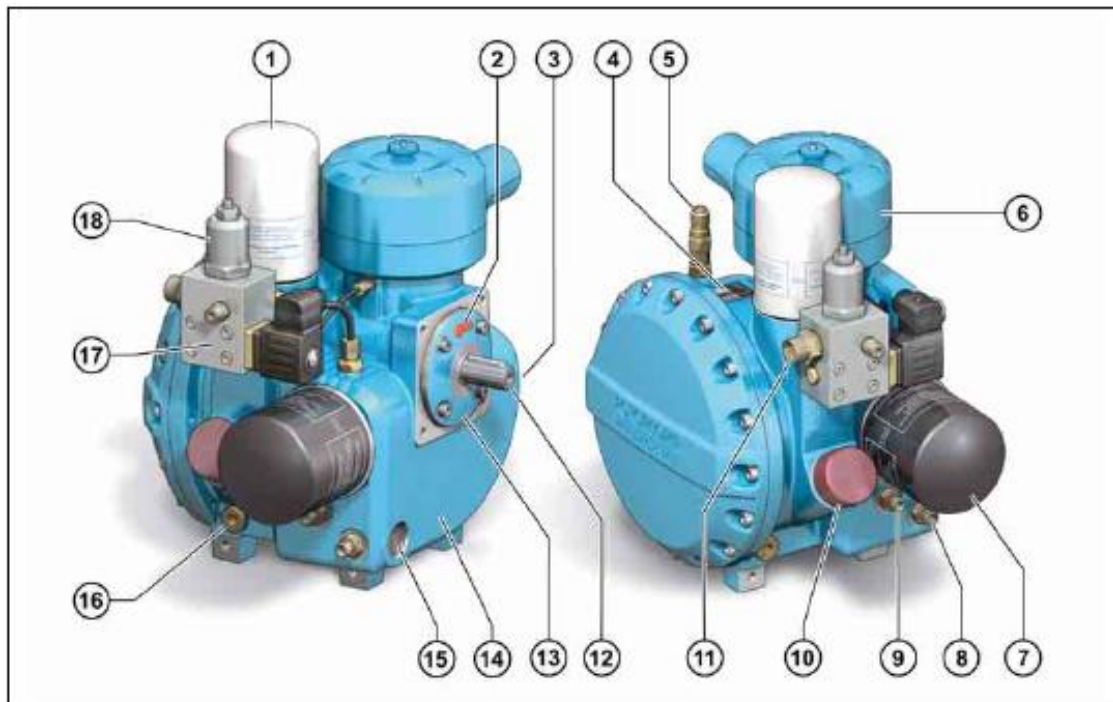

Figure 3-1 EVO1-NK compact module (sample depiction)

1. Air-oil separating element
2. Rotation direction preset
3. Temperature sensor connection
4. Nameplate
5. Safety valve (optional)
6. Intake valve with air filter
7. Oil filter
8. Oil circulation connection/outlet
9. Oil circulation connection/inlet
10. Oil filler opening
11. Compressed air outlet
12. Drive shaft
13. End cover with shaft seal
14. EVO1-NK basic module
15. Oil thermostat
16. Oil drain screw
17. Control unit, electric
18. Minimum pressure valve

 **Note:**

Please consult the installation drawing for details.

3-1

3.1.2 EVO2-NK compact module

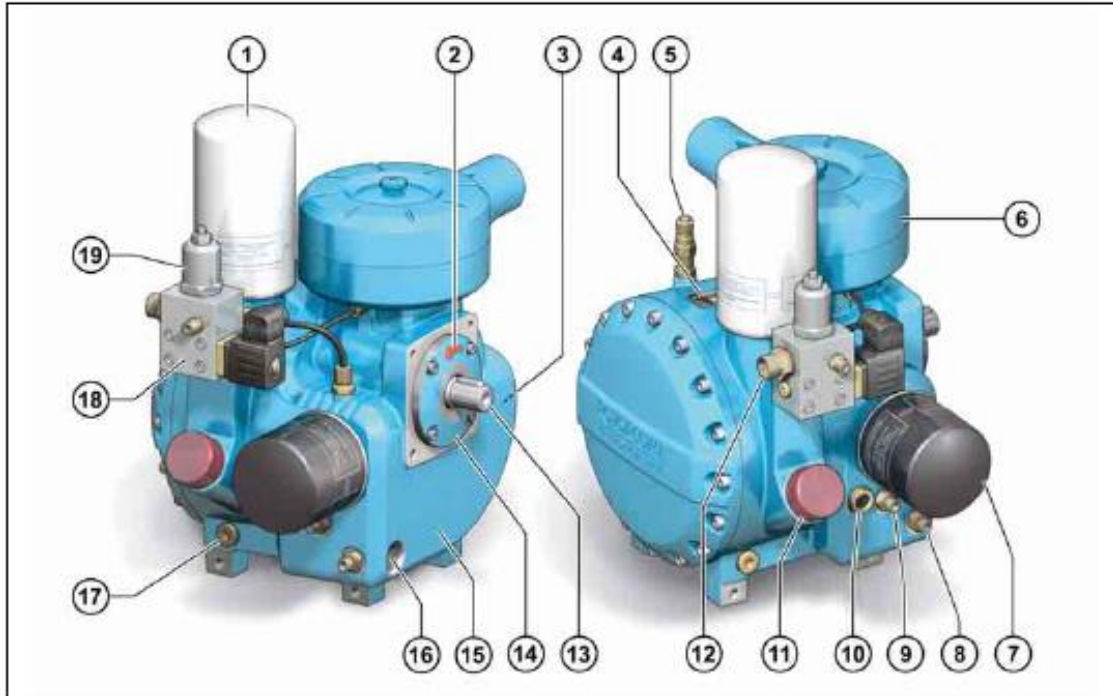

Figure 3-2 EVO2-NK compact module (sample depiction)

1. Air-oil separating element
2. Rotation direction preset
3. Temperature sensor connection
4. Nameplate
5. Safety valve (optional)
6. Intake valve with air filter
7. Oil filter
8. Oil circulation connection/outlet
9. Oil circulation connection/inlet
10. Oil sight glass (optional)
11. Oil filler opening
12. Compressed air outlet
13. Drive shaft
14. End cover with shaft seal
15. EVO2-NK basic module
16. Oil thermostat
17. Oil drain screw
18. Control unit, electric
19. Minimum pressure valve

 **Note:**

Please consult the installation drawing for details.

3.1.3 EVO3-NK compact module

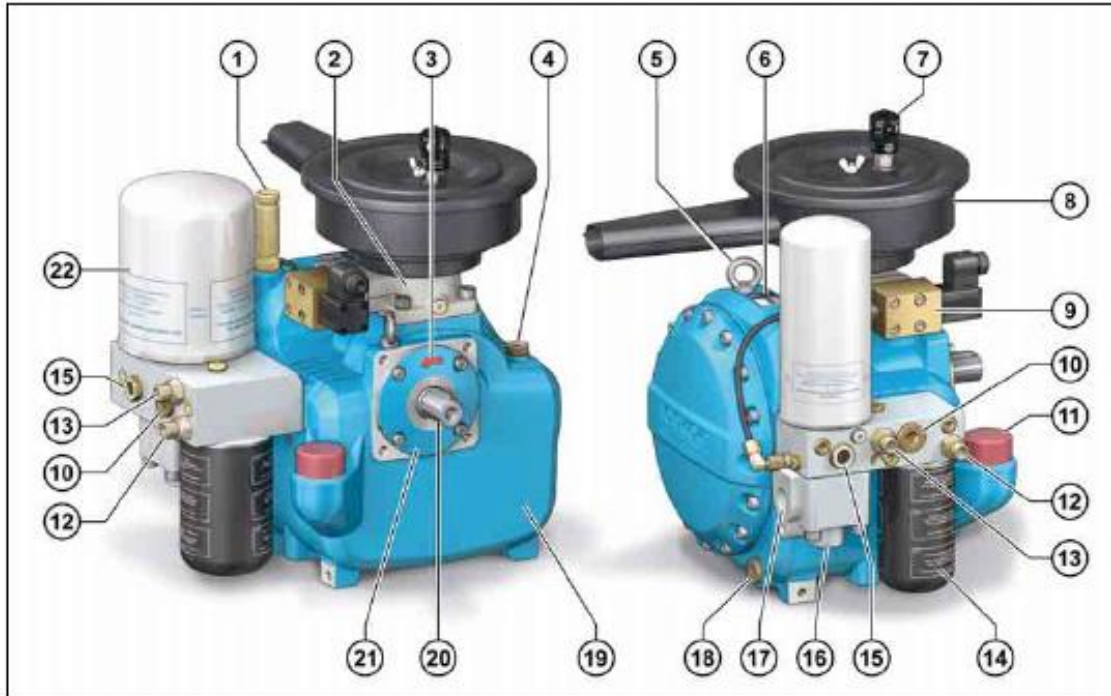

Figure 3-3 EVO3-NK compact module (sample depiction)

1. Safety valve (optional)
2. Intake valve
3. Rotation direction preset
4. Temperature sensor connection
5. Transport eyes
6. Nameplate
7. Maintenance indicator (optional) for intake filter
8. Intake filter
9. Control unit, electric
10. Oil thermostat
11. Oil filler opening
12. Oil circulation connection/inlet
13. Oil circulation connection/outlet
14. Oil filter
15. Oil return line check
16. Minimum pressure valve
17. Compressed air outlet
18. Oil drain screw
19. EVO3-NK basic module
20. Drive shaft
21. End cover with shaft seal
22. Air-oil separating element



Note:

Please consult the installation drawing for details.

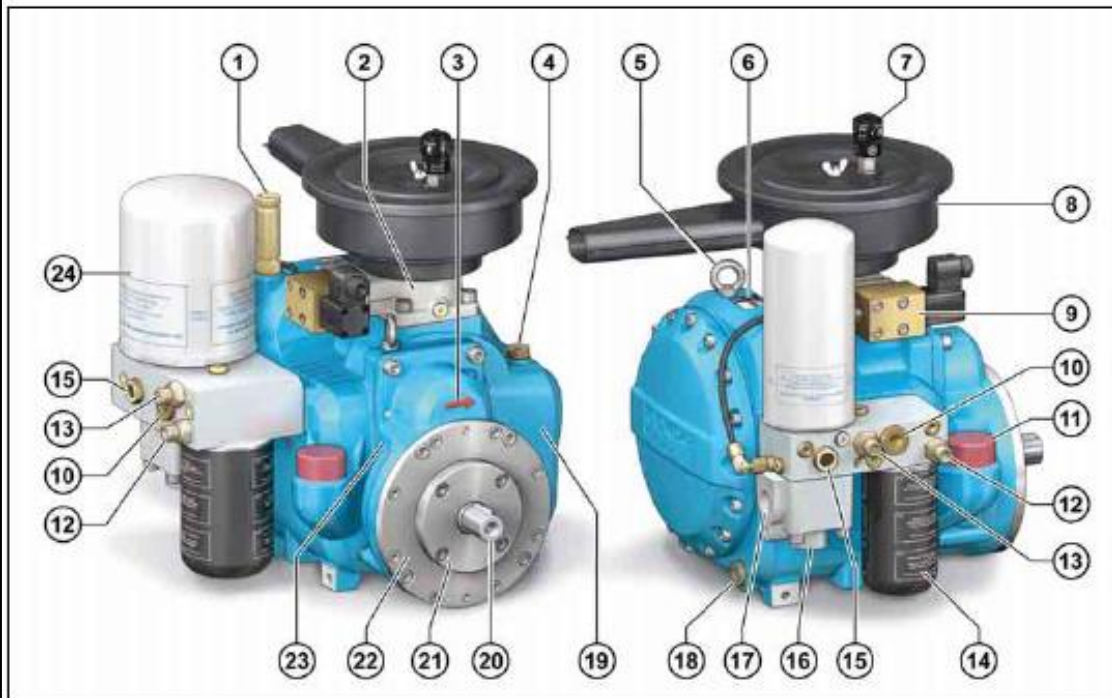

Figure 3-4 EVO3-NK-G compact module (sample depiction)

1. Safety valve (optional)
2. Intake valve
3. Rotation direction preset
4. Temperature sensor connection
5. Transport eyes
6. Nameplate
7. Maintenance indicator for intake filter (optional)
8. Intake filter
9. Control unit, electric
10. Oil thermostat
11. Oil filler opening
12. Oil circulation connection/inlet
13. Oil circulation connection/outlet
14. Oil filter
15. Oil return line check
16. Minimum pressure valve
17. Compressed air outlet
18. Oil drain screw
19. EVO3-NK basic module
20. Drive shaft
21. End cover with shaft seal
22. Transmission
23. Identification transmission ratio (numbers of teeth)
24. Air-oil separating element

 **Note:**

Please consult the installation drawing for details.

3.1.4 EVO6-NK compact module

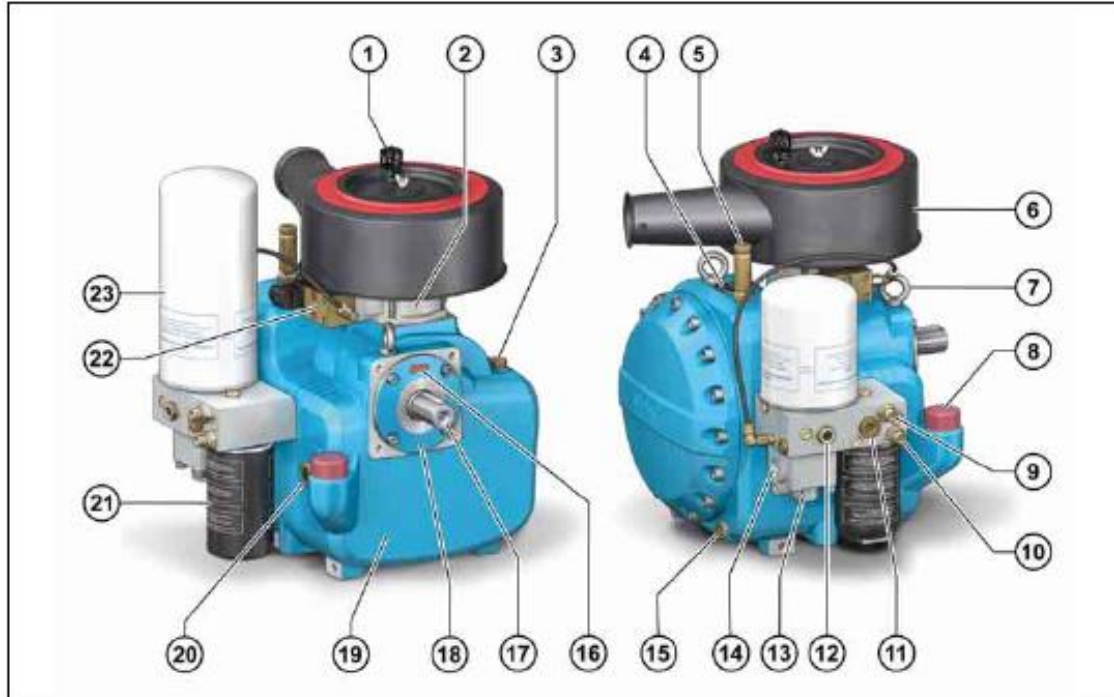

Figure 3-5 EVO6-NK compact module (sample depiction)

1. Maintenance indicator for intake filter (optional)
2. Intake valve
3. Temperature sensor connection
4. Nameplate
5. Safety valve (optional)
6. Intake filter
7. Transport eyes
8. Oil filler opening
9. Oil circulation connection/outlet
10. Oil circulation connection/inlet
11. Oil thermostat
12. Oil return line check
13. Minimum pressure valve
14. Compressed air outlet
15. Oil drain screw
16. Rotation direction preset
17. Drive shaft
18. End cover with shaft seal
19. EVO6-NK basic module
20. Oil sight glass (optional)
21. Oil filter
22. Control unit, electric
23. Air-oil separating element

 **Note:**

Please consult the installation drawing for details.

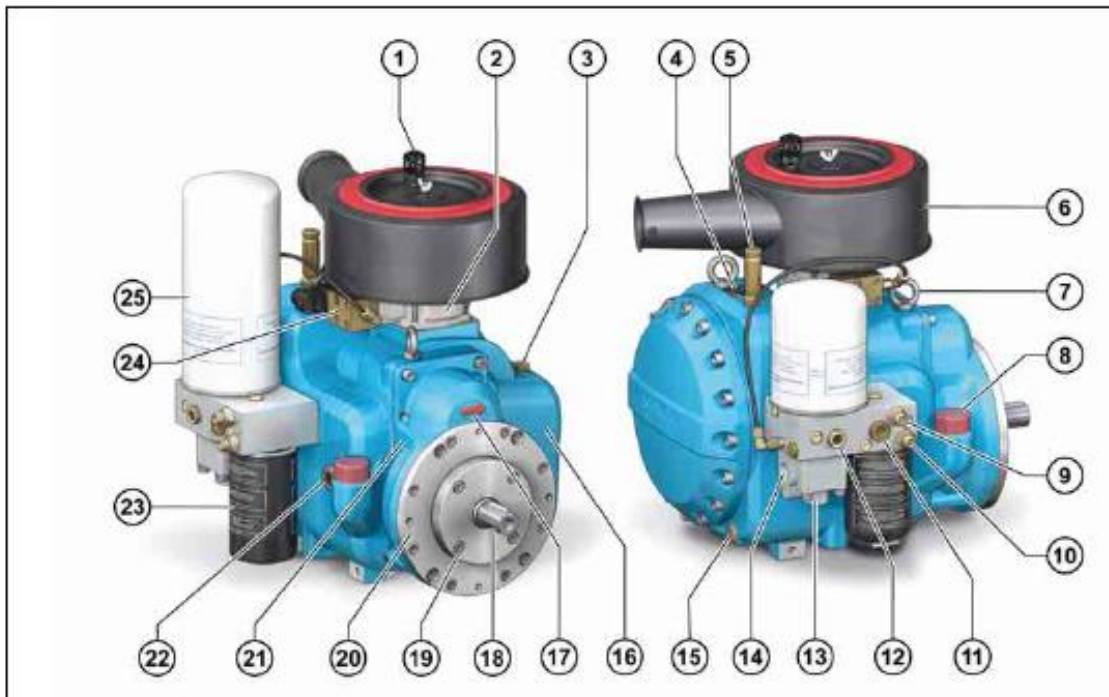

Figure 3-6 EVO6-NK-G compact module (sample depiction)

1. Maintenance indicator for intake filter (optional)
2. Intake valve
3. Temperature sensor connection
4. Nameplate
5. Safety valve (optional)
6. Intake filter
7. Transport eyes
8. Oil filler opening
9. Oil circulation connection/outlet
10. Oil circulation connection/inlet
11. Oil thermostat
12. Oil return line check
13. Minimum pressure valve
14. Compressed air outlet
15. Oil drain screw
16. EVO6-NK basic module
17. Rotation direction preset
18. Drive shaft
19. End cover with shaft seal
20. Transmission
21. Identification transmission ratio (numbers of teeth)
22. Oil sight glass (optional)
23. Oil filter
24. Control unit, electric
25. Air-oil separating element



Note:

Please consult the installation drawing for details.

Installation and operating manual – EVO-NK

3.1.5 EVO9-NK compact module

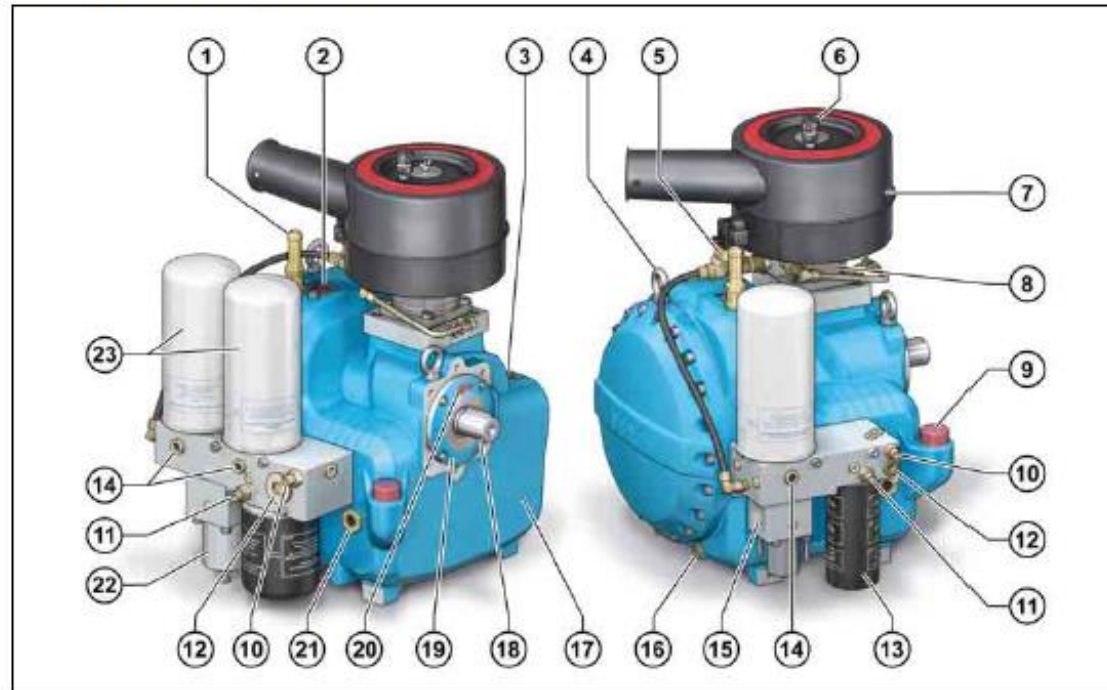

Figure 3-7 EVO9-NK compact module (sample depiction)

1. Safety valve (optional)
2. Nameplate
3. Temperature sensor connection
4. Transport eyes
5. Control unit, electric
6. Maintenance indicator for intake filter (optional)
7. Intake filter
8. Intake valve
9. Oil filler opening
10. Oil circulation connection/outlet
11. Oil circulation connection/inlet
12. Oil thermostat
13. Oil filter
14. Oil return line check
15. Compressed air outlet
16. Oil drain screw
17. EVO9-NK basic module
18. Drive shaft
19. End cover with shaft seal
20. Rotation direction preset
21. Oil sight glass (optional) monitoring the oil level (sight glass; optional)
22. Minimum pressure valve
23. Air-oil separating element



Note:

Please consult the installation drawing for details.

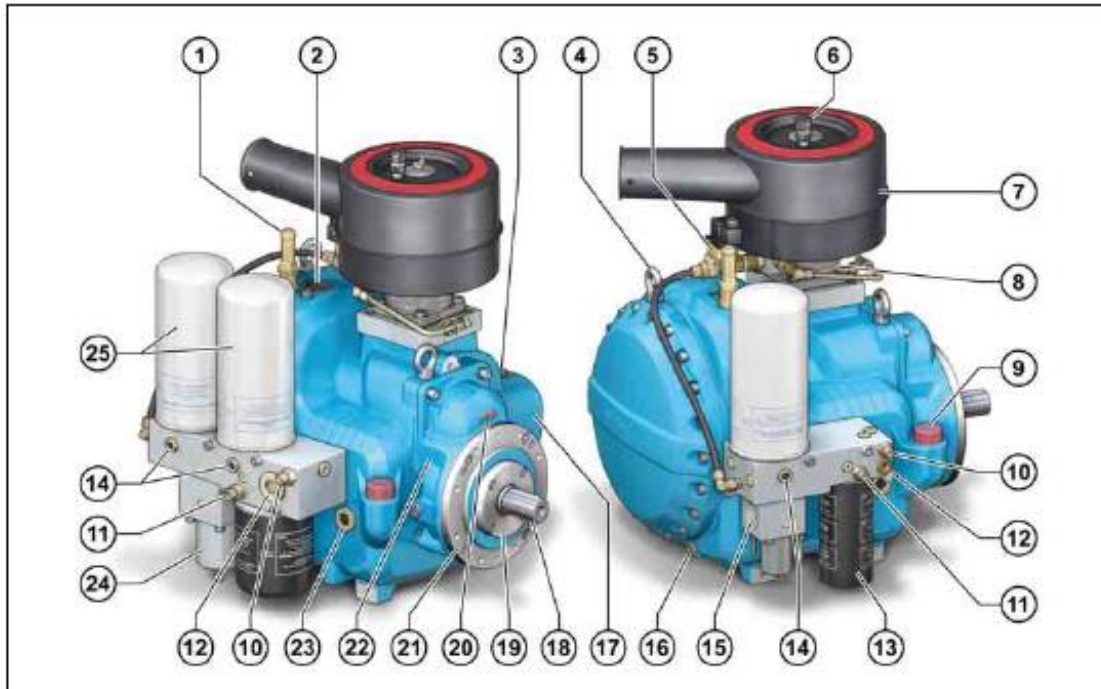

Figure 3-8 EVO9-NK-G compact module (sample depiction)

1. Safety valve (optional)
2. Nameplate
3. Temperature sensor connection
4. Transport eyes
5. Control unit, electric
6. Maintenance indicator for intake filter (optional)
7. Intake filter
8. Intake valve
9. Oil filler opening
10. Oil circulation connection/outlet
11. Oil circulation connection/inlet
12. Oil thermostat
13. Oil filter
14. Oil return line check
15. Compressed air outlet
16. Oil drain screw
17. EVO9-NK basic module
18. Drive shaft
19. End cover with shaft seal
20. Rotation direction preset
21. Transmission
22. Identification transmission ratio (numbers of teeth)
23. Oil sight glass (optional)
24. Minimum pressure valve
25. Air-oil separating element

 **Note:**

Please consult the installation drawing for details.

Installation and operating manual – EVO-NK

3.2 Specifics by transmission version

The transmission is supplied with oil via the compact module screw compressor (internal oil circulation) and is acted on with pressure during operation. The transmission-drive shaft seal simultaneously serves as the seal between the pumping medium and the environment.

The transmission is not suitable for having its oil refilled or emptied.

On the model with a transmission, the rotation direction is clockwise when looking at the shaft (it rotates to the right).

It is not permissible to provide the transmission with a belt drive. Radial or axial forces are not permissible.

The drive must be exerted via a coupling that decouples the transmission shaft from axial, radial, and angular deviations.

The numbers of teeth of the transmission gears are stamped onto the top of the transmission housing (see Figs. 3-4, 3-6 and 3-8). If it becomes necessary to change the transmission ratio, please consult ROTORCOMP VERDICHTER GmbH.

3.3 Operating description for the EVO-NK compact module screw compressor

3.3.1 EVO-NK flow diagram

The flow diagram shows a schematic view of the operating principle and the arrangement of the main components of the EVO-NK compact module screw compressor, regardless of any other equipment.

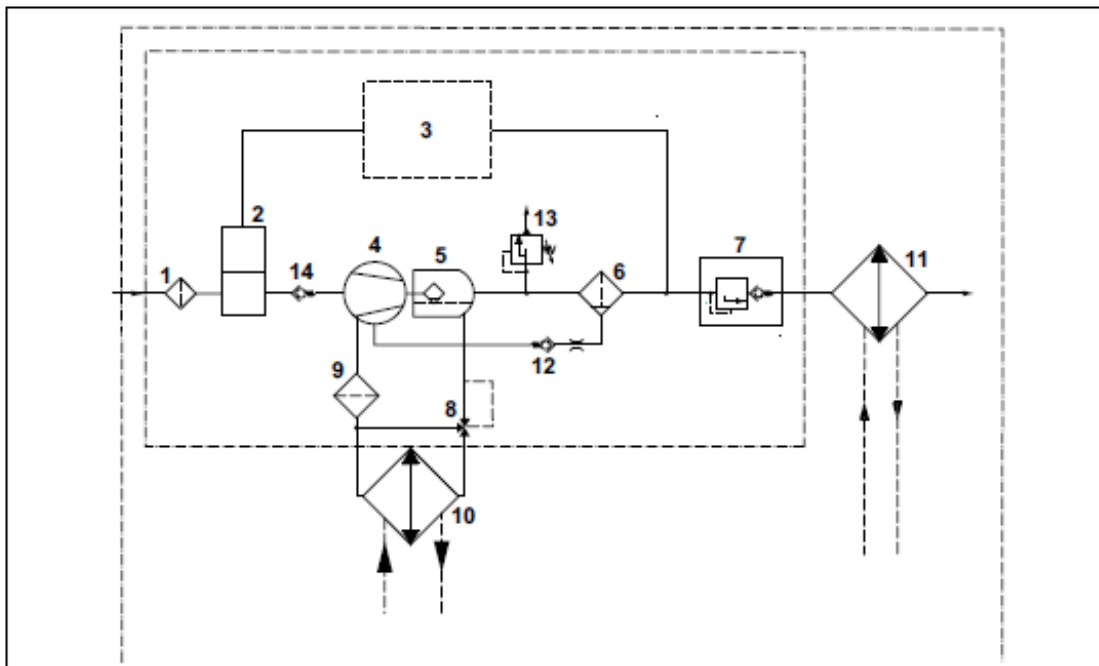

Figure 3-9 EVO-NK flow diagram

- | | |
|--|-----------------------------|
| 1. Intake filter | 8. Oil thermostat |
| 2. Intake valve | 9. Oil filter |
| 3. Control unit, electric | 10. Oil cooler (optional) |
| 4. Screw compressor | 11. Air cooler (optional) |
| 5. Separating tank with pre-separation | 12. Non-return valve |
| 6. Air-oil separating element | 13. Safety valve (optional) |
| 7. Minimum pressure valve | 14. Non-return valve |

Installation and operating manual – EVO-NK

3.3.2 Operating description

The air drawn in flows via the intake filter 1 through the intake valve 2 into the compression chamber 4 of the compact module screw compressor. In the compression chamber, the intake air is compressed and oil for lubrication and cooling is injected.

The oil-air mixture then enters the separating tank 5 in which the majority of the oil is separated from the air. The air travels to the compressed air outlet via the air-oil separating element 6 and the minimum pressure valve 7 and travels into the compressed air system via the air cooler 11 and/or if necessary an owner-installed compressed-air reservoir.

In the air-oil separating element 6, the oil is filtered out down to a residual content of $< 3 \text{ mg/m}^3$ and is then conveyed back into the compressor housing via a nozzle and the non-return valve 12.

When the compressor module is switched off, the minimum pressure valve 7 with a non-return function prevents backflow of the compressed air out of the system into the compression chamber in the discharge phase.

During startup a faster pressure buildup is also ensured, which is required for optimum lubrication and oil separation.

The heat resulting during compression is dissipated via the oil-air mixture. The oil circulation also results from the pressure difference between the outlet and inlet pressure. The optimum operating temperature for the oil is adjusted by the integrated oil thermostat 8. Depending on the oil temperature, the oil thermostat valve routes the oil flow via the oil cooler 10 or directly to the oil filter 9.

The oil then flows via the oil filter 9 to the various injection points in the compressor block.

3.4 Intake valve

The EVO-NK is equipped with an integrated intake valve that is mounted directly on the compressor housing. In the electric version, the intake valve is triggered via a solenoid valve and in the pneumatic version, it is triggered via a proportional regulator.

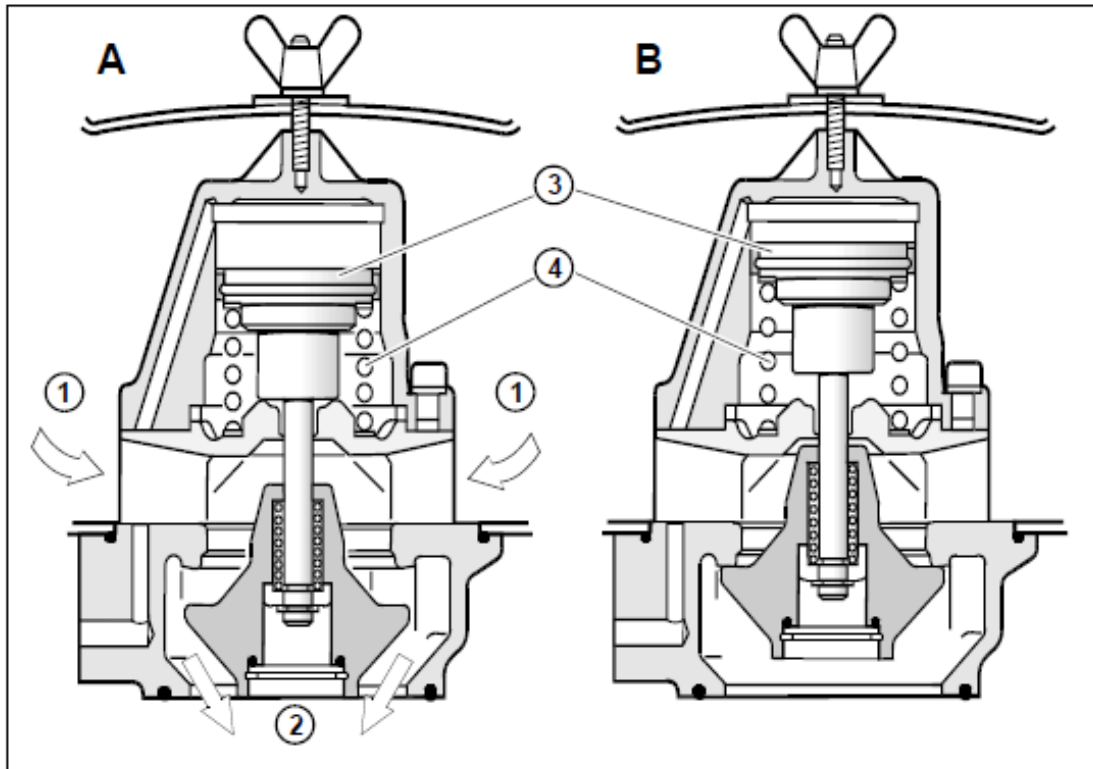

Figure 3-10 Intake valve
(sample depiction)

- A Intake valve open
- B Intake valve closed
- 1. Air inlet
- 2. Air outlet
- 3. Control piston
- 4. Spring

3-12

3.4.1 Installation position

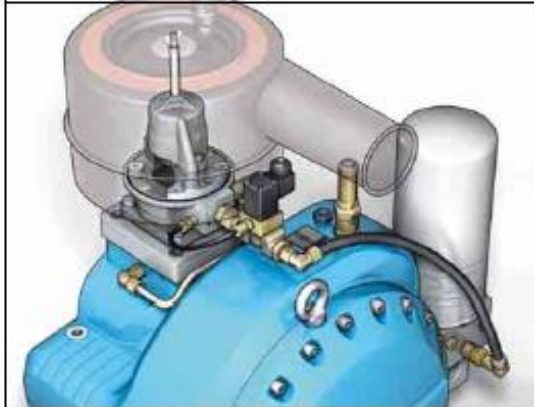

Figure 3-11 Installation position of intake valve (sample depiction)

3.5 Intake air filter

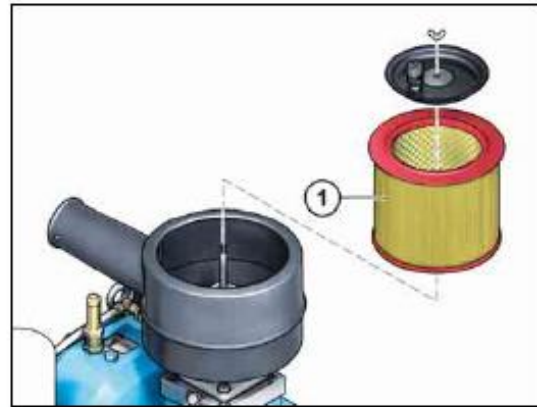

Figure 3-12 Intake air filter (sample depiction)

The intake air filter is mounted directly over the intake valve (see Figure 3-12).

The micro air filter element 1 with a fineness of 10 µm is used for the filtering of intake air.

The constant degree of separation of almost 100% on all loading levels, the resistance to heat, cold, water, oil, and fuel and a large filter area that permits a long service life make the air filter element the ideal fine filter for filtering intake air of compressor systems.

The micro dry filter cartridges are recommended as a 1-stage filter with a low filter resistance for standard applications.

⚠ Attention:

Special applications, e.g. system installation in a heavily soiled environment, mobile systems, etc., require 2-stage filters with a somewhat higher filter resistance, but also a better degree of separation for the protection of the compressor system.

3.5.1 Intake filter monitoring

- Maintenance indicator, optical (optional)
- Maintenance indicator, electric (optional)

3.6 Multiblock

The EVO3-NK/EVO3-NK-G, EVO6-NK/EVO6-NK-G, and EVO9-NK/EVO9-NK-G compact module screw compressors are equipped with a multiblock into which the oil thermostat, the oil filter, the air-oil separating elements, the minimum pressure valve, the non-return valve with the oil return line, and the oil return line check are integrated.

The module variants permit a very wide component selection (e.g. size and number of fine separators, size of oil filter, minimum pressure valve, and oil thermostat) as a function of the delivery quantity, the performance, and customer wishes.

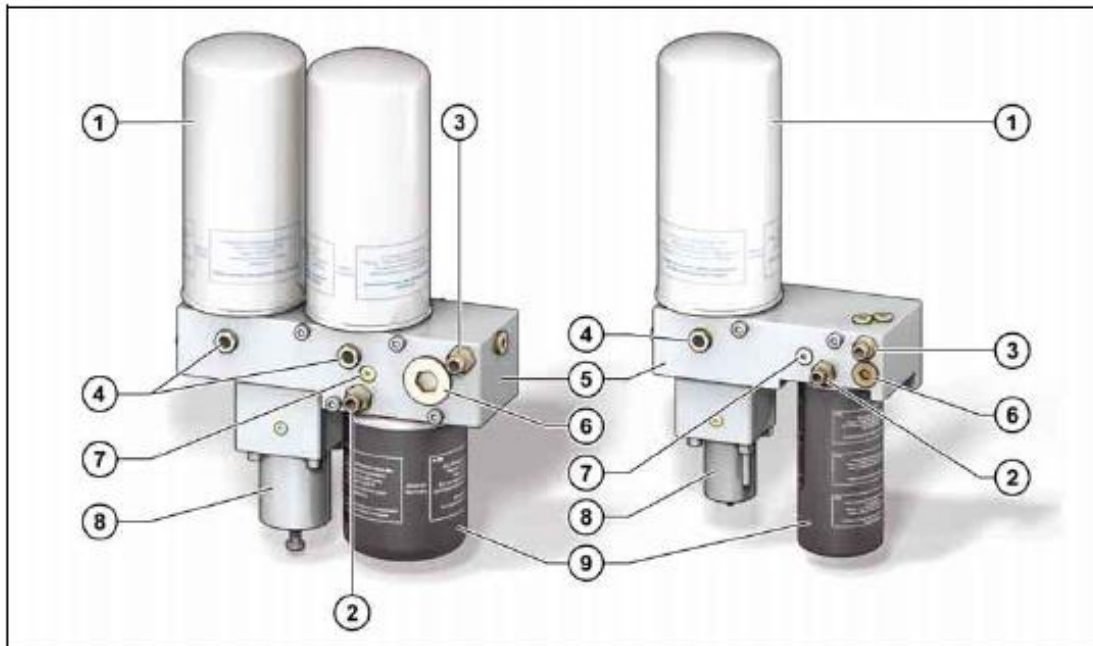

Figure 3-13 Multiblock
(sample depiction)

1. Air-oil separating element
2. Oil circulation connection/inlet
3. Oil circulation connection/outlet
4. Oil return line check
5. Housing
6. Oil thermostat
7. Oil separation return line
(integrated non-return valve)
8. Minimum pressure valve
9. Oil filter

Installation and operating manual – EVO-NK

3.7 Oil intake non-return valve

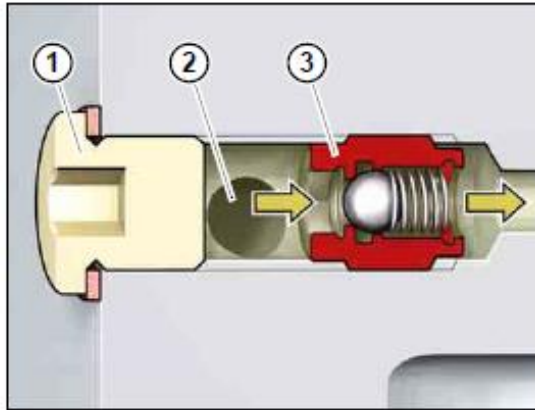

Figure 3-14 Oil intake non-return valve

1. Screw plug
2. Return line for oil separation
3. Non-return valve with external thread G 1/4"

The oil intake non-return valve 3 prevents flooding of the air-oil separating elements with oil flowing back out of the screw compressor due to the pressure difference in the system when the screw compressor system is switched off.

3.8 Air-oil separating element

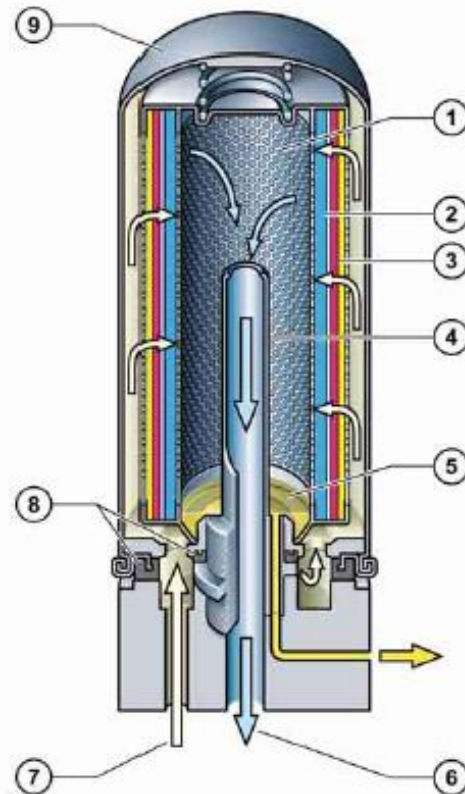

Figure 3-15 Air-oil separating element

1. Inlet of air-oil mixture
2. Fine separator
3. Post-separator
4. De-oiled compressed air
5. Pressure-resistant support pipe
6. Outlet of de-oiled air
7. Separated oil
8. Seals
9. Pressure-resistant housing

3-15

Installation and operating manual - EVO-NK

The air-oil separating element is used to recover the extremely finely distributed residual oil in the form of droplets following the pre-separation.

The air-oil separating element separates virtually all of the residual oil out from the compressed air. An optimum pre-separation in the separating tank is required – an improved pre-separation permits an improved fine separation.

The vertical cartridge is flowed against from below, while the residual oil is separated out while flowing through the special filter element. Then it is fed into the oil circulation again.

Installation and operating manual – EVO-NK

3.8.1 Minimum pressure valve

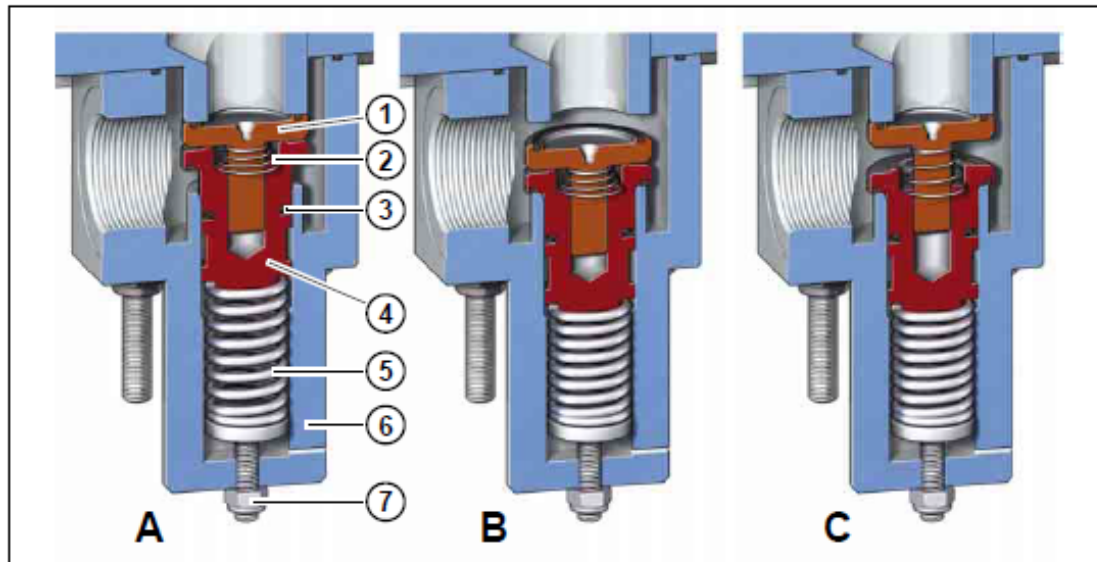

Figure 3-16 Minimum pressure valve

- A Minimum pressure valve closed
- B Minimum pressure valve open
- C Minimum pressure valve open, non-return valve closed
- 1. Non-return valve plate
- 2. Non-return valve spring
- 3. Seal
- 4. Pressure holding valve piston
- 5. Pressure holding valve spring
- 6. Pressure holding valve housing
- 7. Adjustment screw / counternut

The minimum pressure valve is adjustable and can be fastened in two positions – with the air outlet toward the rear or toward the left (viewed from the drive side).

The minimum pressure valve is located on the outlet of the compressor upstream of the air cooler and is used as a:

a) Pressure holding valve

When there is no counter-pressure, it prevents the pressure from dropping below the minimum pressure set at the pressure holding valve (factory setting approx. 5.5 bar). This pressure is necessary to ensure the oil supply of the compressor. At the same time this is the condition for good oil separation.

b) Non-return valve

It prevents compressed air from flowing back out of the system or the owner's compressed-air reservoir into the compact module screw compressor. As a result, the system can be completely discharged when the separating tank is switched off.

This valve operates automatically.

⚠ Attention:

The minimum pressure valve integrated into the compact module screw compressor is not an overflow valve for continuous operation (it is only used for the starting sequence until the higher operating pressure is reached and subsequently determines a higher system pressure).

3.9 Oil filter

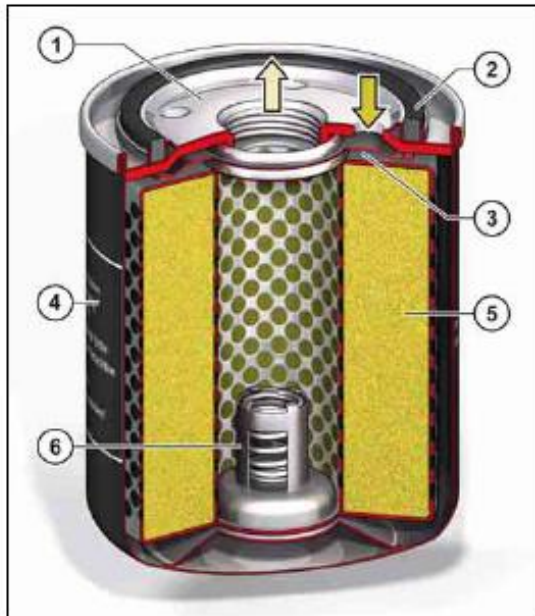

Figure 3-17 Oil filter

1. Cover
2. Seal
3. Return line shut-off valve
4. Filter housing
5. Filter element
6. Bypass valve

The filter fineness of the oil filter is 20 µm.

The replacement filter has a bypass valve which opens with cold, high-viscosity oil or a heavily soiled filter with a pressure difference of 2.5 bar. This eliminates the undersupply of the screw compressor with oil, which results in the maximum permissible compression temperature being exceeded.

3.10 Oil thermostat

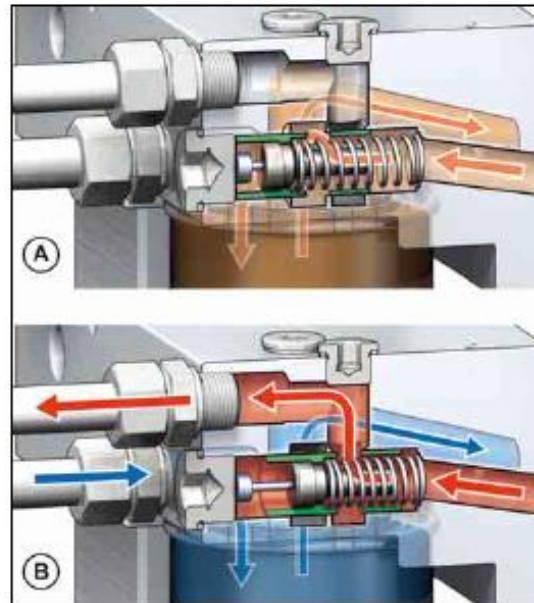

Figure 3-18 Oil thermostat

- A Oil thermostat closed
- B Oil thermostat open

The EVO-NK is equipped with an integrated oil thermostat. This is located in the housing or in the multiblock housing in front of the oil filter and is accessible from the outside (left side – viewed from the drive side).

The oil thermostat working element can be replaced and must be selected in accordance with the required operating temperature.

The oil thermostat opens the connection to the oil cooler when the operating temperature is reached and controls the maintenance of the optimum temperature of the system as the process continues. In the startup phase the operating temperature is reached faster, and therefore the formation of condensate in the oil circulation is largely avoided. Depending on the compressor operating data, the temperature must be between 80 °C and 110 °C/176 °F and 230 °F (measured at compressor outlet).

When designing the cooling system, the pressure dew point graph (Figure 8-1) must be taken into account.

Please contact ROTORCOMP VERDICHTER GmbH if you have questions about the pressure dew point.

Installation and operating manual – EVO-NK

The oil thermostat is maintenance-free. Operation of the compressor system with an impermissible overtemperature can result in a damage to the working element, which can lead to an overheating of the screw compressor system. Consequently, ROTORCOMP VERDICHTER GmbH recommends replacing the oil thermostat working element when changing the oil and filter.

 **Note:**

When the system is operated at 15 bar, the thermostat working element must always be adapted to the increased requirements.

3.11 Oil cooler/air cooler (optional)

With air-cooled screw compressor systems, the circulating oil is cooled down from the compressor outlet temperature to the compressor injection temperature.

As an option, ROTORCOMP VERDICHTER GmbH offers combination coolers with aluminum fins, which are connected to the gas and oil circulation of the respective compressor (see Fig. 3-20).

The cold ambient air is fed through the cooler with the aid of a fan.

The corresponding coolers are dimensioned so that they ensure operating safety at an ambient temperature of up to 45 °C/113 °F. Sufficient cooling air parameters are assumed.

3.12 Safety valve (SV) (optional)

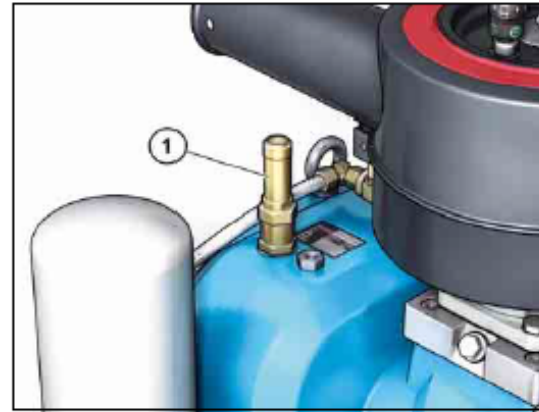



Figure 3-19 Safety valve (optional)

 **Warning:**

A safety valve must be installed prior to commissioning. Operation of the system without a safety valve can be **life-threatening!**

The safety valve 1 is located on the basic module, and is provided with a test device.

While taking the pressure loss in the oil separating system into account, the opening pressure is a maximum of 1 to 5 bar above the respective operating pressure of the system. However, the opening pressure of the SV must not exceed 16.5 bar.

 **Note:**

Pressures that deviate from this require written approval from ROTORCOMP VERDICHTER GmbH!

The valve is type-tested and leaded.

3-19

3.13 Air-oil circulation outside the compressor module

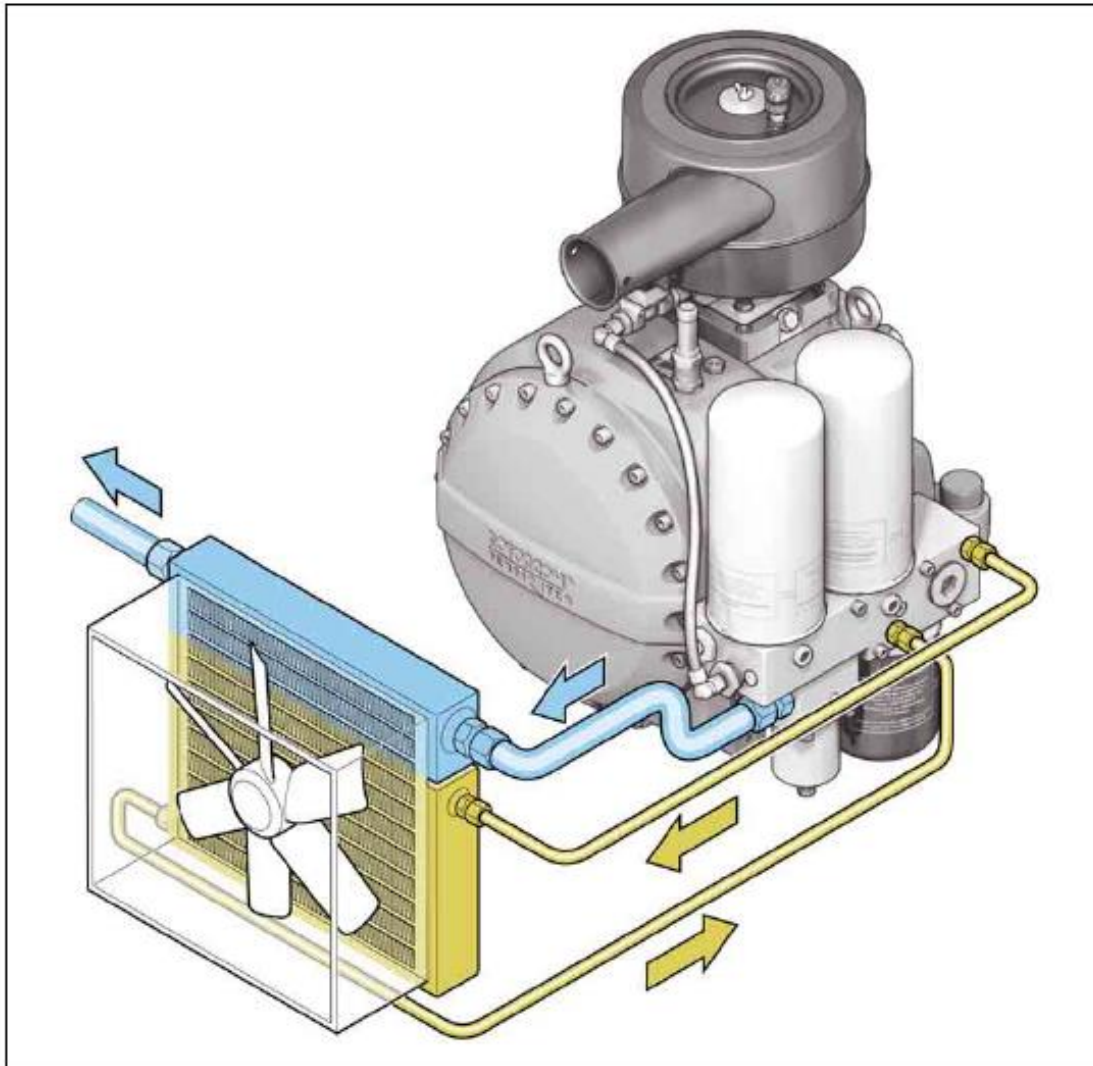

Figure 3-20 Air-oil circulation
(sample depiction)

After the oil-air mixture in the fine separator cartridge has been deoiled, the compressed air flows through the air cooler (optional) and from there to the consumer.

The oil flows via a thermostat (see chapter 3.10 "Oil thermostat") to the oil cooler of the combination cooler.

The cooled oil flows from the oil cooler via the oil filter back into the internal oil-air circuit of the compact module screw compressor.

3-20

Installation and operating manual – EVO-NK

5 Installation and assembly, disassembly, storage

5.1 Connection thread/assembly

5.1.1 Fastening screws

The NK housing is provided with threaded holes for fastening. Only screws with matching **metric thread** are to be screwed into these threaded holes.

 **Attention:**

- The maximum permissible tightening torque for all screw connections may not be exceeded. Refer to VDI 2330 (see chapter 9.6 "Tightening torques").
 - Only screws suitable for fastening the compressor housing may be used for this purpose.
-

5.1.2 Pipe connections

Pipe connections with a female thread for a compressed-air outlet, oil circulation, draining lines, and control lines are provided on the compact module screw compressor. Only fittings or screw connections with **cylindrical inch thread (BSP)** suitable for these female threads are to be screwed into them.

 **Attention:**

- **Conical threads** must not be used because they can damage the housing of the compressor module when they are screwed in (see installation drawing).
- All connection lines for gas, oil and control lines must be connected to the compressor module so that no pulling, pressure, or bending forces can be introduced into the housing via the connection lines (flexible connections).

5.1.3 Piping materials

 **Attention:**

Plastic lines and rubber hose lines can be corroded by the oil used in the compact module screw compressor.

Use suitable material for the lines.

5.2 Safety precautions for installation and assembly



Warning:

- It is absolutely mandatory to follow the safety instructions contained in chapter 2 "Safety precautions".
- It is not permissible to install and operate the compact module screw compressor in the vicinity of flammable or combustible materials.
- Secure the compressor module to prevent it from tipping over.
- Suitable lifting equipment must be used for lifting the compressor module.
- Under no circumstances should the compressor module be lifted by its drive shaft or attachments; use only the transport eyes.
- Do not stand or walk under the raised compressor module!
- Before attaching to pressurized system parts, the system must be effectively cut off from all pressure sources and a pressure relief of the entire system must be carried out.
RISK OF INJURY due to escaping compressed air or oil!
- Do not perform welding work or any other work that requires or produces heat near the oil system.
- The compressor block must be provided with a sufficiently dimensioned ground.
- A safety valve must be installed prior to commissioning.
Operation of the compressor system without a safety valve can be **life-threatening!**



Attention:

- Check whether the electrical data of the compressor module and compressor system match.
- All blind flanges, plugs, caps and bags with desiccant must be removed before mounting the pipes. Screw fittings and pipe connections must be of the correct size and must be suitable for the respective operating pressure.
- The gas drawn in must not contain caustic or aggressive vapors.

- Make sure that the pressure line from the compressor to the cooler or air system can expand as a result of the heat and does not come into contact with flammable materials.
- No external force may be exerted on the air outlet valve; the connected pipe connection must be mounted torque-free.

5.3 Installation

Ensure good accessibility to the service points when installing the compact module screw compressor:

- Oil filling point
- Oil drain point
- Removal of the separator cartridge (removal dimensions according to offer drawing)
- Removal of the oil filter cartridge (observe the removal dimensions specified in the offer drawing)
- Easy cleaning of the oil cooler
- Replacement of the shaft seal (removal and installation of the end cover and the bearing race)
- Belt drive and clutch (accessibility, specifications for correct belt tension)



Attention:

- The compact module screw compressor must be installed in a place in which the ambient air is as cool and clean as possible. Never cover the air inlet. It must be ensured that the penetration of moisture with the intake air is kept to a minimum.
- Screw compressors must always be installed in stable fashion on a level surface and must be aligned with a level if necessary.
In exceptional cases, e.g. with mobile systems, these may only be operated up to a maximum angle of inclination of 10°.

Installation and operating manual – EVO-NK

The base frame for the following fastening versions must be torsionally rigid and level. The fastening of the compressor module to a base frame together with the drive motor can be designed in accordance with the following versions.

5.3.1 Fastening to base frame with screw fitting

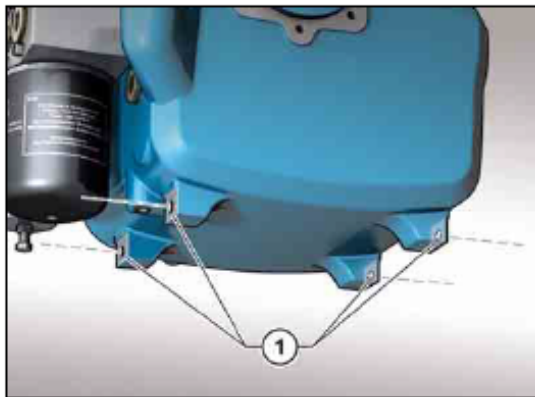

Figure 5-1 Fastening to base frame (sample depiction)

⚠ Attention:

The compact module screw compressor may only be fastened at the side holes on the compressor housing provided for this purpose.

The unit must be fastened torque-free to the respective fastening points 1 on the left and right on the base frame.

5.4 Drive

The compact module screw compressor is designed to be driven by electric motors, internal combustion engines, hydraulic motors, etc. The power can be transmitted indirectly via a belt drive (V-belt, toothed belt, etc.) or directly via a flexible coupling.

The rotation direction is counterclockwise when looking at the shaft (it rotates to the left). On the model with a transmission, the rotation direction is clockwise when looking at the shaft (it rotates to the right).

⚠ Attention:

In the design of the drive unit, it is in general necessary to ensure that the drive shaft has axial clearance and should under no circumstances be subjected to compressive or tensile stress.

5.4.1 Belt drive

⚠ Attention:

Transmission versions of the compact module screw compressor must **not** be provided with a belt drive.

Improper design and/or installation of the V-belt drive can result in a considerable reduction in bearing life and/or breakage of the drive shaft.

In the event of drive shaft breakage and/or premature bearing damage, ROTORCOMP VERDICHTER GMBH can only honor the warranty if the belt drive has been properly designed and implemented.

The following information must be observed for this purpose.

- The belt drive must not be over-dimensioned. Maximum design power for a belt drive at the max. speed for this compressor module see chapter 9 "Technical Data and Tightening Torques".
- The belt pulley must be pushed onto the drive shaft as far as possible and secured.
- Observe the belt tension forces and tensioning direction for the different belt types (V-belt, flat belt, toothed belt, etc.).

5-3

- The V-belt pulleys must be balanced. It is not permissible to drive the belt pulley onto the drive shaft by striking it with a hammer, and this can result in bearing damage.
- When aligning the belt drive, exact parallel alignment without vertical and horizontal angular errors must be ensured.
- A torsionally rigid base frame for the belt drive must be installed so that it aligns exactly with the compressor module.
- A "fluttering" of the belt of the belt drive should be structurally prevented (axial spacing of pulleys, belt tension, and stability of the base frame and tensioner).

5.4.2 Direct drive

 **Attention:**

Offset and angular errors result in damage to bearings and drive shaft!
 ROTORCOMP VERDICHTER GmbH recommends installation with an elastic coupling. The coupling must decouple the transmission shaft from axial, radial, and angular deviations. The alignment of the motor and compact module screw compressor must be carried out according to the instructions of the elastic coupling manufacturer.

The compressor module is provided with a centering flange for directly coupled units.

The flanged unit must be fastened stress-free on the base frame. The connection dimensions of the flange are contained in the offer drawing.

5.5 Air outlet

The pressure loss at the air outlet due to air coolers, fittings, piping, etc. should be as slight as possible.

 **Note:**

Cross-sections of the outlet pipe must be generously dimensioned. Avoid pressure losses due to elbow screw fittings. The outlet pipe must be connected to the outlet in a stress-free fashion.

 **Warning:**

Operation without a safety valve may result in serious injuries to personnel and damage to equipment!
 Operation without a safety valve on the separating tank is not permitted.

 **Attention:**

A possible compressed air temperature (at the outlet) of up to 110°C/230°F requires the components connected downstream, e.g. the compressed-air hose, pressure switch, air cooler, fittings, etc. to be designed for this temperature. ROTORCOMP VERDICHTER GMBH recommends installing an air cooler. When used without an air cooler, the final customer must be informed of the high outlet temperature.

5.6 Oil cooling

Warning:

Storage time and service life when using hydraulic hoses:

- It is not permissible for the service life of the hose lines to exceed a maximum of 6 years, including storage time of at most 2 years (Except from DIN 20066).
The service life is understood to include the duration of use and possibly storage of a hose starting from the manufacture date.
- When a hose line is manufactured, the hose (hose by the meter) must not be older than four years old.

Lay the cooler connection lines safely to prevent tripping, catching, damage, wedging, detachment, falling, etc.

Attention:

The cooler connection lines must be connected torque-free to the oil connections.
The following information on the design and execution of the oil cooling system must be observed.

- The oil cooling system must be designed so that the oil outlet temperature is a maximum of 105°C/220°F at the maximum intended ambient temperature.
The pressure losses in the cooler circuit should be no greater than 1.5 bar.
- The cooler connection lines must be connected to the oil connections in a torque-free fashion.

Note:

- The oil circulation quantity depends on the final pressure of your application.
- The oil cooler must be installed so that it can be cleaned easily.

5.7 Disassembly/decommissioning

Warning:

- It is absolutely mandatory to follow the safety instructions contained in chapter 2 "Safety precautions".
- Before disassembly of pressurized system parts, the system must be effectively cut off from all pressure sources and a pressure relief of the entire system must be carried out.
RISK OF INJURY due to spurting oil or escaping compressed air!
- When lifting and transporting the compact module screw compressor, it is absolutely mandatory to follow all safety instructions contained in chapter 4 "Transport".
- All disassembly work must be performed only with the compressor system and power supply switched off. When doing so, the system must be secured to prevent it from being accidentally switched on.
- Secure the compressor module to prevent it from tipping over.

Attention:

- Catch oil residues in suitable containers.
- Oil filter cartridges, air-oil separating elements, lubricant residues, used oil, and other materials contaminated with oil must be disposed of in accordance with the applicable regulations.
- After decommissioning, the parts of the compressor module must be disposed of and/or recycled in accordance with the applicable laws.

6 Commissioning



Warning:

It is absolutely mandatory to follow the safety instructions contained in chapter 2 "Safety precautions".

6.1 Preparation for commissioning

The components of the compact module screw compressor are carefully checked and tested at the factory. These tests ensure that the required performance and checking data are complied with. The compressor module must nevertheless be monitored during the first operating hours.

- Filling the compact module screw compressor with oil (see chapter 7.5.3 "Filling with oil").



Warning:

Compliance with the applicable regulations of the specific country with regard to commissioning is mandatory. In Germany these include the Operating Safety Ordinance.

The following points must be observed prior to commissioning:

- A safety valve must be installed prior to commissioning.
Operation of the screw compressor system without a safety valve can be **life-threatening!**
- Check all screw fitting and fastening screws for firm seating.
RISK OF INJURY due to spurting oil or escaping compressed air!
- The max. final pressure specified on the nameplate may not be exceeded.
- Before each first commissioning and when recommissioning after a longer shut-down of the screw compressor compact module, always carry out the activities described in Chapter 6.4 "Resuming operation of the screw compressor system".



Attention:

- Be sure to observe the rotation direction (see chapter 6.2 "Checking rotation direction").
- Do not use the EMERGENCY OFF button or main switch to switch off a compact module screw compressor running under load.
- Checking the oil level (see chapter 7.4 "Oil level")
- With a belt drive: checking the belt tension and belt routing (see chapter 7 "Maintenance and repair").
- Checking the position of the shut-off valve (by the operator).

6.2 Checking rotation direction

Rotation direction:

Standard model rotating to the left (counterclockwise) looking at the shaft.

Transmission model rotating to the right (clockwise) looking at the shaft.



Attention:

The rotation direction of the screw compressor system must be checked during commissioning and each time changes are made to the electrical supply line of the electric motor drive. For this purpose, switch on the drive motor briefly and then switch off again immediately.

Rotation for more than 2 seconds in the wrong rotation direction will destroy the compact module screw compressor. If necessary, reverse the connections of the connecting cable.

6.3 Test run

 **Attention:**

- The screw compressor system must not be started when the feed chamber is completely filled with oil. There is the risk of considerable damage.
- In the Stop mode with the (owner's) shut-off valve open, the compressor system is discharged down to the minimum pressure valve opening pressure extremely quickly! This can cause the oil in the separating tank to foam up.

The possible consequences include:

- Oil escaping with the discharge air
- Oil flooding the air-oil separating elements
- Oil-laden compressed air when restarting the system.

During the test run, make sure to do the following:

- Operate the compressor system until it has reached its steady-state temperature. This should ensure that the compact module screw compressor does not subsequently become impermissibly hot or is not operated at too low of a temperature.
- Listen for abnormal running noise.

After the test run:

- Check the compressor system for leaks.
- Check the oil level (see chapter 7.4 "Oil level").

6.4 Resuming operation of the screw compressor system

 **Warning:**

Before resuming operation, the electrical equipment and all safety-relevant units must be checked for leaks and proper function. Loose connections must be refastened and damaged lines must be replaced.

Screw compressor systems that are switched off, shut down, or stored for longer than three months cannot be placed into operation again until after the following steps have been carried out:

- Manually rotate the compact module screw compressor in the rotation direction several times.
- With the compressor system stopped, add approx. 0.2 l of oil (same oil type as in the oil separating tank) into the rotor chamber.
- Once again, manually rotate the compressor module compressor stage in the rotation direction several times.
- Check the oil level in the separating tank and top up if necessary (see chapter 7 "Maintenance and repair").
- Monitor operation of the compressor system for at least 15 minutes, but at least until the steady-state temperature is reached (continuous operating temperature) (see chapter 6.3 "Test run").

7 Maintenance and repair

7.1 Safety precautions



Warning:

The owner must ensure that all maintenance and repair work is carried out by authorized, qualified specialists that have sufficiently informed themselves ahead of time through careful study of the installation and operating manual. Following commissioning, the owner bears all responsibility and liability for equipment.

In all maintenance and repair work:
RISK OF ACCIDENTS!

- It is absolutely mandatory to follow the safety instructions contained in chapter 2 "Safety precautions".
- If it is necessary to lift and transport the compact module screw compressor, it is absolutely mandatory to follow all safety instructions contained in chapter 4 "Transport".
- All maintenance and repair work must be performed only with the screw compressor system and power supply switched off. When doing so, the system must be secured to prevent it from being inadvertently switched back on.
- Use personal safety equipment!
- Before removing pressurized parts, the compressor system must be effectively cut off from all pressure sources and a pressure relief of the entire system must be carried out.
RISK OF INJURY due to spurting oil or escaping compressed air!
- Suitable lifting equipment must be used if it is necessary to lift the compact module screw compressor or its components.
- Under no circumstances should the compressor module be lifted by its drive shaft or attachments; use only the transport eyes.
- Do not stand or walk under the raised compressor module!
- Do not perform welding work or any other work that requires or produces heat near the oil system.

- After maintenance, testing, adjustment, and repair work, the electrical equipment and all safety-relevant units must be checked for leaks and proper function. Loose connections must be refastened and damaged lines must be replaced.



Attention:

- Only use permissible or suitable tools for maintenance and repair work.
- Only use genuine spare parts.
- Only use the operating materials described above. When handling oils, greases, and other chemical substances, comply with the safety regulations that are applicable for the product!
- Always ensure absolute cleanliness during maintenance and when conducting repair work. Keep dirt away from the system. Cover parts and exposed openings with a clean cloth, paper or strips of adhesive tape.
- Make sure that no tools, loose parts, cleaning cloths, or the like are left behind in or on the compressor system.
- Before releasing the compressor system for operation following maintenance or repair, check whether the operating pressures, temperatures, time settings, and oil level are correct, and whether the control and switch-off devices are functioning properly.



Note:

All maintenance work conducted must be entered immediately in the check sheet.

7.2 Maintenance and spare parts

Maintenance and spare parts, see 8 "Lubricants and operating materials" and spare parts list.

7.3 Cleaning



Warning:

- Cleaning work on the compact module screw compressor must be performed only with the screw compressor drive unit and power supply switched off. When doing so, the system must be secured to prevent it from being inadvertently switched back on.
- Never use flammable solvents or carbon tetrachloride to clean the compressor module. Take precautions against toxic vapors or cleaning agents.
- The unit parts, oil, and oil filler plug can be hotter than 80°C.
RISK OF BURNS!
Allow the compressor system to cool.
- Wear safety goggles when using compressed air to clean the compressor module.



Attention:

- Electrical components, control devices, etc. must be protected against the penetration of moisture, e.g. from a steam jet.
- Catch cleaning agents in suitable containers.
- Cleaning agents and containers and cloths contaminated with them must be disposed of in accordance with the applicable regulations.

7.4 Oil level

An important factor for the operating safety of the compressor system is the oil level in the oil reservoir.

The oil level check must be carried out before commissioning the compact module screw compressor and then repeated every 100 operating hours.

There are two methods for performing the oil level check:

- Via the oil filler opening
- Via the oil-level sight glass (optional; starting from the EVO2-NK size).

The exact oil level check can only be carried out via the oil filler opening.



Warning:

Rotating and pressurized components.
RISK OF INJURY!

7.4.1 Oil level check via oil filler opening



Warning:

The unit parts, oil, and screw plug 1 can be hotter than 80 °C!
RISK OF BURNS!
Wear personal safety equipment!



Attention:

- With hot oil, the oil level can be approx. 10 mm higher than with cold oil shortly after discharging.
As a result, oil may escape when the screw plug is opened at the maximum oil level. In this case, close the screw plug again immediately and carefully remove the oil that has escaped.
- Only check the oil level when the compressor system is in a horizontal position.

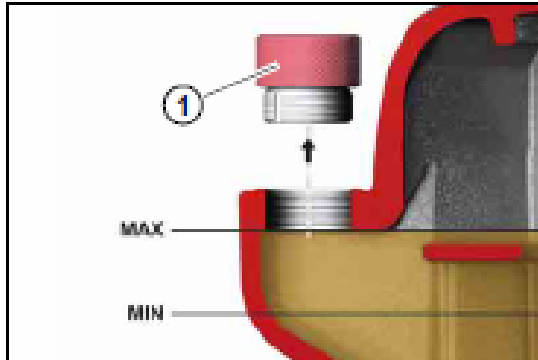

Figure 7-1 Oil level check via oil filler opening (sample depiction)

Note:

The screw cap of the oil filler neck is provided with a safety hole on the side from which oil or air escapes if there is any residual pressure in the separating tank. Wait briefly in this case.

- Switch off the system, prevent it from being switched back on without authorization, and bring it into a horizontal position.
- Wait for one minute at standstill.
- Unscrew the screw plug 1 of the filler neck by hand with the oil level depressurized.
- Check the oil level.
- If necessary, top up oil of the same oil type and the same brand up to the maximum level.

Note:

The oil filler neck is positioned so that it is not possible to overfill the system. Excess oil runs out of the filler neck again.

- Screw on the screw plug 1 firmly by hand.
- Switch on the system.
- Check the oil filler plug for leaks and replace the O-ring if necessary.
- Carefully remove escaped, excess oil.

7.4.2 Oil level check via sight glass (optional) (starting from the EVO2-NK size)

Warning:

Unit parts can be hotter than 80°C!
RISK OF BURNS!
Wear personal safety equipment!

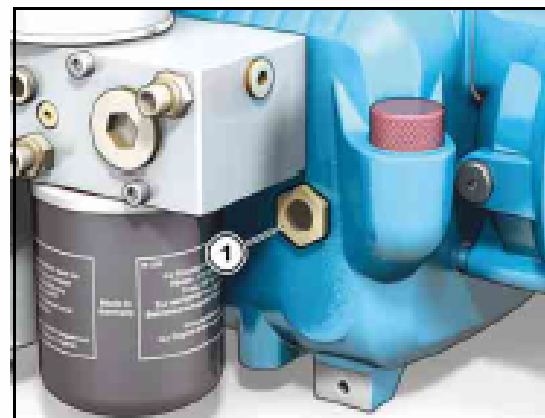

Figure 7-2 Oil level check via sight glass (optional; sample depiction)

The oil-level sight glass 1 is mainly intended for an oil level check when the screw compressor system is stopped.

When the compressor system is stopped, oil must be visible in the sight glass; if it is not, then it is necessary to add oil (see chapter 7.4.1 "Oil level check via oil filler opening").

7.5 Oil change

Warning:

- Rotating and pressurized components.
RISK OF INJURY!
- The unit parts, oil, and oil filler plug may be hotter than 80°C.
RISK OF BURNS!
Wear personal safety equipment!
- The oil change must only be carried out when the compressor system is stopped and completely depressurized.
- Immediately remove liquids on the floor.
RISK OF SLIPPING!

7.5.1 Oil change Intervals

According to the specifications of the system manufacturer. Reference values for the compact module screw compressor, see chapter 7.10 "Maintenance Intervals".

7.5.2 Oil drain point

The compressor system must be at operating temperature in this case.

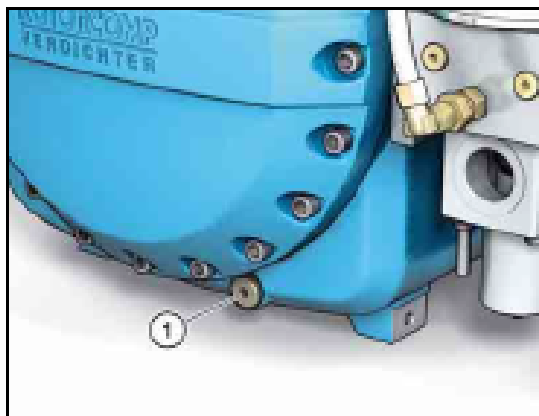

Figure 7-3 Oil drain screw (sample depiction)

- Switch off the system and prevent it from being switched back on without authorization.
- Depressurize the system completely.
- Slowly unscrew the screw plug of the oil filler neck by hand.
- Carefully unscrew the oil drain screw 1 and catch the used oil in a suitable container.



Attention:

Dispose of the used oil and the oil-contaminated container and cloths in accordance with the applicable regulations.

- Clean the oil drain screw 1 and screw in again.

7.5.3 Filling with oil



Attention:

- The transmission is not suitable for having its oil refilled or emptied.
- Only add oil when the compressor system is in a horizontal position.
- Make sure to use recommended oil (see chapter 8 "Lubricants and operating materials"). Add oil of the same oil type from the same manufacturer. Switching over to another oil type can require flushing of the compact module screw compressor.

ROTORCOMP VERDICHTER GmbH recommends also replacing the oil filter during an oil change.

- If necessary, replace the oil filter (see chapter 7.6.2 "Replace oil filter").
- Bring the system into a horizontal position.
- Via the filler neck on the separating tank, add oil up to the maximum level and screw the screw plug 1 firmly onto the filler neck by hand (see Fig. 7-1).
- Switch on the screw compressor and allow it to run for approx. three minutes.
- Oil level check: Top up the missing oil quantity again up to the maximum level.
- Check sheet entry (see chapter 7.9 "Maintenance check sheet (template)").

7.6 Oil filter



Warning:

- Rotating, pressurized and hot components, **RISK OF INJURY!**
- The unit parts, oil, and oil filter plug can be hotter than 80°C, Risk of burns! Wear personal safety equipment!
- The oil filter change must only be carried out when the screw compressor system is stopped and completely depressurized.

7.6.1 Oil filter replacement intervals

According to the specifications of the system manufacturer. Reference values for the compact module screw compressor, see chapter 7.10 "Maintenance intervals".



Attention:

In compressor modules, the oil filter must be replaced with each oil change.

7.6.2 Replace oil filter

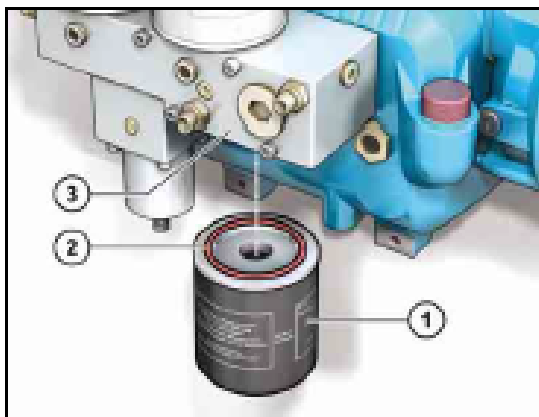

Figure 7-4 Oil filter replacement (sample depiction)

- Switch off the screw compressor system and prevent it from being switched back on without authorization.
- Depressurize the system completely.
- Remove the oil filter cartridge 1 with a suitable tool, e.g. oil filter strap wrench.



Attention:

Dispose of the old oil filter cartridge in accordance with the applicable regulations.

- Oil the seal 2 on the new oil filter cartridge 1 with oil of the same oil type as in the compact module screw compressor.
- The new oil filter cartridge 1 must be held vertically and filled with oil of the same oil type as in the compressor module before being screwed on.
- Screw the new oil filter cartridge onto the multiblock 3 and tighten by hand. No tool is required.
- Switch on the system.
- The oil filter must then be checked for leaks with the system running.
- Check the oil level (see chapter 7.4.1 "Oil level check via oil filler opening"), top up the missing oil quantity again up to the maximum level.
- Check sheet entry (see chapter 7.9 "Maintenance check sheet (template)").

7-5

7.7 Air-oil separating element



Warning:

- Rotating and pressurized components.
RISK OF INJURY!
- Unit parts and oil can be hotter than 80 °C.
RISK OF BURNS!
Wear personal safety equipment!
- The air-oil separating elements must only be replaced when the compressor system is stopped and completely depressurized.

7.7.1 Maintenance Intervals

According to the specifications of the system manufacturer. Reference values for the compact module screw compressor, see chapter 7.10 "Maintenance Intervals".



Attention:

Heavily soiled intake air or low-quality oil cause heavier soiling of the cartridge, which can result in the premature need for replacement.

7.7.2 Changing the air-oil separating element

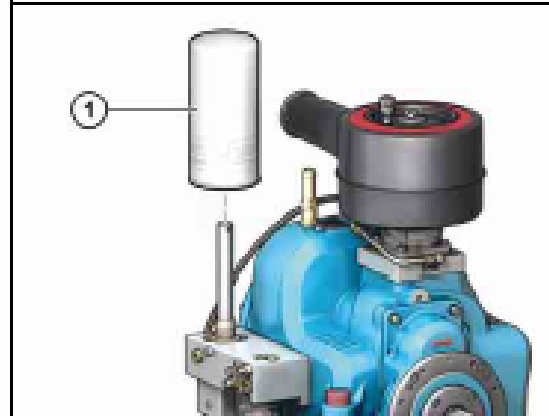

Figure 7-5 Changing the air-oil separating element (sample depiction)

- Switch off the screw compressor system and prevent it from being switched back on without authorization.
- Unscrew the air-oil separating element 1 with a suitable tool, e.g. oil filter strap wrench.



Attention:

Dispose of the old air-oil separating elements in accordance with the applicable regulations.

- Oil the seal on the new air-oil separating element 1 with oil of the same oil type as in the compact module screw compressor.
- Tighten the new air-oil separating element by hand. No tool is required.
- Switch on the compressor system.
- The fine separator must be checked for leaks with the system running.
- Check sheet entry (see chapter 7.9 "Maintenance check sheet (template)").

7.8 Intake air filter

7.8.1 Maintenance Intervals

According to the specifications of the system manufacturer. Reference values for the compact module screw compressor, see chapter 7.10 "Maintenance Intervals".

In case of heavily soiled intake air, an earlier replacement of the filter element is necessary when the optical or electric maintenance indicator (optional) indicates this (perm. vacuum up to 50 mbar).

7.8.2 Replacing air filter element

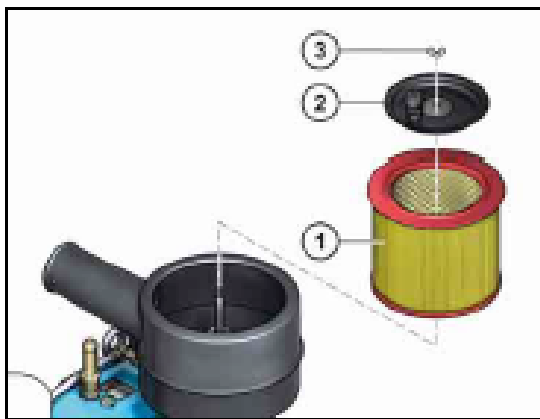

Figure 7-6 Changing the air filter element (sample depiction)

Attention:

- Dirt and dust particles must not be permitted to get into the air inlet of the compressor module.
- It is not permissible to clean the filter element; the filter element must always be replaced in case of soiling!
- Dispose of the old air filter element according to the applicable regulations.

- Switch off the screw compressor system and prevent it from being switched back on without authorization.
- Screw off the wing nut 3 and remove the filter cover 2.
- Remove the old filter element 1.
- Carefully remove dust from the filter housing.

- Insert the new filter element in the filter housing.
- Lay on the filter cover, ensuring proper positioning during assembly.
- Tighten the wing nut.
- Switch on the system.
- Conduct a test run and an operating test.

7.10 Maintenance intervals

Attention:

The frequency of the maintenance intervals (oil change, replacement of oil filter, air-oil separating elements, and air filter element) varies depending on the application and the operating parameters. Depending on the design of the system, maintenance interval should therefore be specified by the compressor manufacturer. These must be given priority. It is advisable to conclude a maintenance agreement.

The following table provides an overview of the reference values for the EVO-NK compact module screw compressor.

Maintenance intervals (OH=operating hours)	Maintenance work	See chapter
Before commissioning	Check the oil level in the separating tank	7.4
Once after 50 OH	Check the oil level in the separating tank Tighten all screw pipe fittings and electrical screw terminal fittings; check all other connections for firm seating	7.4
Every 100 OH	System inspection <ul style="list-style-type: none"> • Check oil level in separating tank, top up if oil is low • Check maintenance indicator (optional) • Listen for abnormal running noise during operation ¹⁾ • Check all lines, hoses, and screw fittings for leaks and externally visible damage ²⁾ 	7.4
Every 1,000 - 6,000 OH depending on application Recommendation: at least every 12 months	Changing the air-oil separating element Carry out oil change Replace oil filter Replace filter element in intake air filter Check system for leaks Clean the system	7.7 7.5 7.6 7.8 7.3

1)



Warning:

Immediately switch off the system, have the deficiency remedied

2)



Warning:

Have leaks and damage remedied immediately!
RISK OF INJURY due to spurting oil or escaping compressed air!
It is not permissible to repair hydraulic hoses.

Maintenance Intervals (OH=operating hours)	Maintenance work	See chapter
Every 2 years with increased demand (multi-shift operation, mobile units)	Replace hose lines (if attached to the compressor module) ^{3*)}	
Every 6 years with normal demand	Replace hose lines (if attached to the compressor module) ^{3*)}	

3*)



Warning:

It is not permissible to repair hose lines.

8 Lubricants and operating materials

8.1 Oil recommendation

Attention:

- RC compact module screw compressors must be operated with an oil that is suitable for special applications. This oil must be approved by the oil manufacturer for use in screw compressors. It must even be suitable under unfavorable operating conditions, such as soiling of the intake air with gases, solvent vapors and exhaust gases and at high ambient temperatures.
- The materials, substances, and seals used in the compressor module must be taken into account when selecting the oil type. Corrosion and other material damage may not occur.
- Compliance with oil viscosity is imperative; failure to do so poses a risk to the bearing service life.
- It is not permissible to mix different oils.

The oil in the compressor module must meet the following requirements, among others:

- High resistance to aging
- High dispersive power
- Flash point: above 200 °C/392 °F
- Minimum foaming
- High corrosion protection
- Operating temperature: up to 110 °C/230 °F
- Select suitable viscosity class, e.g. ISO VG 68.
- Viscosity class:
In most cases, an oil of the viscosity class ISO VG 100 is required, but a minimum viscosity of approx. 10 cSt (0.387 ft²/h) up to 30 cSt (1.162 ft²/h) at operating temperature must be maintained. In this case, the possible reduction in the viscosity due to oil degeneration over the duration of operation must be taken into account.

Note:

Respect intellectual property rights of third parties! Intellectual property rights of third parties must also be respected when using special cooling and lubricating substances.

Suitable oil types and oil manufacturers can be specified for screw compressor on request. Refined oils (mineral oils), synthetic oils, and bio oils (biodegradable) can be used for the screw compressor oil.

8.1.1 Multigrade oil

Attention:

- The use of multigrade oils can cause problems in the long run since viscosity improvers are destroyed over time. The oil is then no longer secured in the upper viscosity class and a thermal stability is no longer completely ensured. Therefore, the use of multigrade oils in ROTORCOMP compressors is not authorized.
- Only use oils approved for screw compressors!

8.2 Topping off oil

Use the same manufacturer and the same oil type as is currently in use in the compact module screw compressor.

8.3 Measures at low room temperature

Ensure sufficient room heating.

At ambient temperatures below 0 °C, the screw compressor system must be heated up to at least 20 °C before start-up with an integrated standstill heater (optional).

8.4 Pressure dew point of compressed air

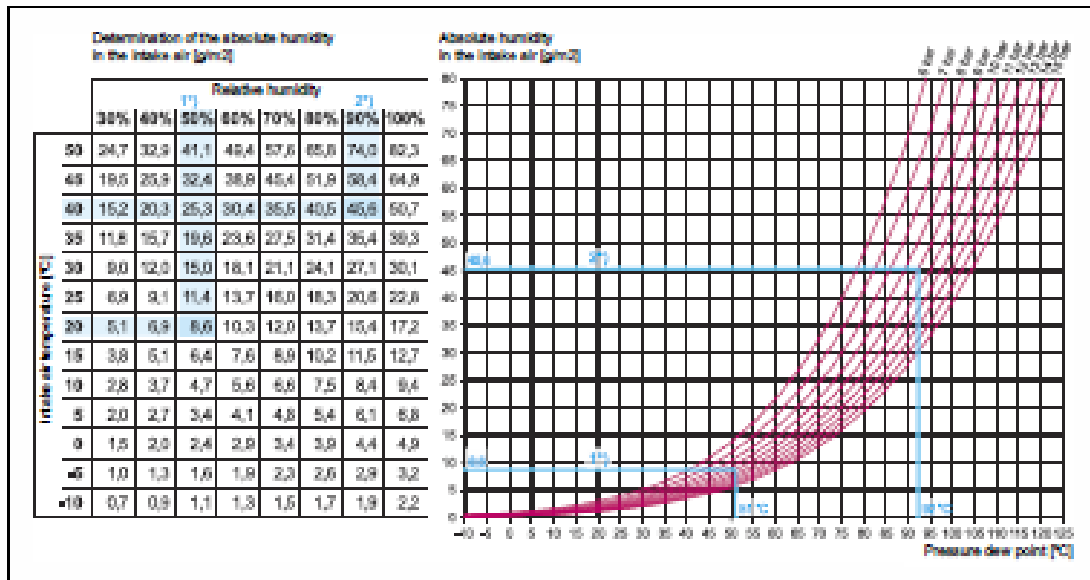

Figure 8-1 Pressure dew point graph

Examples:

- 1) An Intake air temperature of 20 °C and a humidity of 50% result in approx. 8.6 g/m³ of absolute humidity in the intake air.
At a pressure of 10 bar, the pressure dew point is approx. 51°C/124°F.
- 2) An Intake air temperature of 40 °C and a humidity of 90% result in approx. 45.6 g/m³ of absolute humidity in the intake air.
At a pressure of 10 bar, the pressure dew point is approx. 92°C/198°F.

⚠ Attention:

The operating temperature must be above the pressure dew point.

8.5 Temperatures

📄 Note:

The optimum operating temperatures for the screw compressor system can only be achieved if the oil circuit components (thermostat, cooler, fan, etc.) have been properly designed and the supply and exhaust air temperatures of the installation room and the compressor system permit this. The entire thermal economy must be calculated.

8.6 Condensation damage

⚠ Attention:

The relative humidity and the final operating pressures must always be taken into account in accordance with the selection graph for the working temperature of the oil thermostat working element and for the compressor operating temperature in order to prevent condensate from forming in the system.

8.7 Cold starts

During compressor cold starts, the viscosity of the oil must enable the sufficient, immediate supply of the compressor with lubricant following starting while taking into account the higher pressure losses in the oil circulation which is still cold. The higher cold-starting power requirement must not overload the compressor drive.

8.8 Oil separation

The fine oil separation becomes poorer in the upper area with an increasing compressor outlet temperature.

9 Technical Data and Tightening Torques

9.1 EVO1-NK technical data

Compact module screw compressor model		EVO1-NK
Max. operating gauge pressure.	bar(g)	15
	psi (g)	218
Max. delivery quantity according to DIN-ISO 1217.	m ³ /min	0,8
	cfm	28
Power requirement, up to (at the drive shaft)	kW	7,5
	hp	10
Max. speed of main rotor	rpm	7.000
Oil capacity, approx.	l	1,95
Machine weight without oil, approx.	kg	30,5
	lb	67
Compressed-air connection	Inch	G ½"
Max. outlet temperature	°C	110
	°F	230
Max. room temperature	°C	45
	°F	115



Note:

- This table contains only general technical data for this compact module screw compressor.
- Calculation and design are governed by the corresponding data sheet from ROTORCOMP VERDICHTER GmbH.

9.2 EVO2-NK technical data

Compact module screw compressor model		EVO2-NK
Max. operating gauge pressure.	bar(g)	15
	psi (g)	218
Max. delivery quantity according to DIN-ISO 1217.	m ³ /min	1,4
	cfm	49
Power requirement, up to (at the drive shaft)	kW	11
	hp	15
Max. speed of main rotor	rpm	9.000
Oil capacity, approx.	l	3,15
Machine weight without oil, approx.	kg	41
	lb	90
Compressed-air connection	Inch	G 1/2"
Max. outlet temperature	°C	110
	°F	230
Max. room temperature	°C	45
	°F	115



Note:

- This table contains only general technical data for this compact module screw compressor.
- Calculation and design are governed by the corresponding data sheet from ROTORCOMP VERDICHTER GmbH.

9.3 EVO3-NK technical data

Compact module screw compressor model		EVO3-NK	EVO3-NK-G
Max. operating gauge pressure.	bar(g)	15	15
	psi (g)	218	218
Max. delivery quantity according to DIN-ISO 1217.	m ³ /min	2,8	2,8
	cfm	100	100
Power requirement, up to (at the drive shaft)	kW	18,5	18,5
	hp	25	25
Max. speed of main rotor	rpm	9.000	9.000
Oil capacity, approx.	l	4,5	4,5
Machine weight without oil, approx.	kg	54	67
	lb	119	148
Compressed-air connection	Inch	G 1/4"	G 1/4"
Max. outlet temperature	°C	110	110
	°F	230	230
Max. room temperature	°C	45	45
	°F	115	115

 **Note:**

- This table contains only general technical data for this compact module screw compressor.
- Calculation and design are governed by the corresponding data sheet from ROTORCOMP VERDICHTER GmbH.

9.4 EVO6-NK technical data

Compact module screw compressor model		EVO6-NK	EVO6-NK
Max. operating gauge pressure.	bar(g)	15	15
	psi (g)	218	218
Max. delivery quantity according to DIN-ISO 1217.	m ³ /min	5,5	5,5
	cfm	194	194
Power requirement, up to (at the drive shaft)	kW	37	37
	hp	50	50
Max. speed of main rotor	rpm	7.000	7.000
Oil capacity, approx.	l	11	11
Machine weight without oil, approx.	kg	103	128
	lb	227	282
Compressed-air connection	Inch	G 1"	G 1"
Max. outlet temperature	°C	110	110
	°F	230	230
Max. room temperature	°C	45	45
	°F	115	115



Note:

- This table contains only general technical data for this compact module screw compressor.
- Calculation and design are governed by the corresponding data sheet from ROTORCOMP VERDICHTER GmbH.

9.5 EVO9-NK technical data

Compact module screw compressor model		EVO9-NK	EVO9-NK-G
Max. operating gauge pressure.	bar(g)	15	15
	psl (g)	218	218
Max. delivery quantity according to DIN-ISO 1217 through	m ³ /min	8,4	8,4
	cfm	297	297
Power requirement, up to (at the drive shaft)	kW	55	55
	hp	75	75
Max. speed of main rotor	rpm	6.000	6.000
Oil capacity, approx.	l	25	25
Machine weight without oil, approx.	kg	199	224
	lb	439	494
Compressed-air connection	Inch	G 1½"	G 1½"
Max. outlet temperature	°C	110	110
	°F	230	230
Max. room temperature	°C	45	45
	°F	115	115

 **Note:**

- This table contains only general technical data for this compact module screw compressor.
- Calculation and design are governed by the corresponding data sheet from ROTORCOMP VERDICHTER GmbH.

9.6 Tightening torques



Attention:

The maximum permissible tightening torque for all screw connections may not be exceeded.
See VDI 2230.

Unless otherwise specified, the following torques must be used. Always tighten screws/bolts with a torque wrench.

Screw/bolt type	Thread	Max. torque
Hexagonal head bolts Allen screws	M 6	10 Nm (7 ft.lbs)
Hexagonal head bolts Allen screws	M 8	25 Nm (18 ft.lbs)
Hexagonal head bolts Allen screws	M 10	43 Nm (32 ft.lbs)
Hexagonal head bolts Allen screws	M 12	75 Nm (53 ft.lbs)
Hexagonal head bolts Allen screws	M 14	120 Nm (85 ft.lbs)
Hexagonal head bolts Allen screws	M 16	180 Nm (126 ft.lbs)

10 Troubleshooting

The owner must ensure that troubleshooting is carried out by authorized, qualified specialists that have sufficiently informed themselves ahead of time through careful study of the installation and operating manual. Following commissioning, the owner bears all responsibility and liability for troubleshooting.



Warning:

- It is absolutely mandatory to follow the safety instructions contained in chapters 2 "Safety precautions", 5 "Installation and assembly, disassembly, storage" and 7 "Maintenance and repair".
- In the event of malfunctions or damage, the compressor system must be immediately stopped and the deficiency remedied.
- The compressor system may only be placed back into operation after all malfunctions and damage have been remedied.

Fault	Possible cause	Remedy	See chapter	
Not functioning	Control box or electrical connection faulty	Have control box or electrical connection repaired		
Incorrect rotation direction	Phases reversed	Reconnect 2 supply lines		
Screw compressor system has difficulty starting	Motor output insufficient	Inspect		
	Drive transmission ratio too fast	Check		
	Star-delta switchover incorrect	Set		
	Compressor is flooded with oil	Check		
	System has not been depressurized yet	Check, depressurize if necessary		
	Ambient temperature too low	Check the viscosity of the oil		8.1
		Check belt tension		5.4.1
Oil filling too viscous	Check viscosity		8.1	
Pressure losses at filter cartridges	Excessive pressure loss at air-oil separating element	Replace air-oil separating element	7.7.2	

Fault	Possible cause	Remedy	See chapter
Comblstat switches off due to excessively high temperature	Oil shortage	Check the oil level in the oil reservoir, fill if necessary	7.4
	Oil filter soiled	Replace oil filter cartridge	7.6.2
	Oil thermostat faulty	Replace oil thermostat	
	Oil cooler soiled	Clean oil cooler on air side, clean on oil side if necessary	7.3
	Incorrect setup a) Room ventilation b) Exhaust air obstructed c) Thermal short-circuit	Follow recommendations for installation of the compressor system	5.3
	Comblstat defective	Replace comblstat	
Safety valve blows off (at a permissible operating pressure)	Safety valve defective	Replace safety valve	
	Air-oil separating element dirty	Replace air-oil separating element	7.7.2
	Compressor system does not switch off automatically, control valve operates Intermittently	Check the solenoid valve, replace if necessary	
Oil In compressed air	Operating pressure and delivery quantity are not in the permissible range	Check pressures	
	Oil exhaust system contaminated	Clean oil extraction system	7.3
	Air-oil separating element faulty	Check air-oil separating element and replace if necessary	7.7.2
	Oil level in oil reservoir too high; possibly excessive condensate	Observe oil level marking; drain and replace if necessary	7.4

10-2

Fault	Possible cause	Remedy	See chapter
Compressor system is not discharged during continuous operation, system does not switch off automatically in case of intermittent operation, i.e. safety valve blows off	Upper switching point of network pressure monitor set too high	Readjust network pressure monitor	
	Solenoid valve defective Relief valve defective	Replace solenoid valve/ relief valve	
	Minimum pressure valve jams	Check minimum pressure valve for smooth movement; if necessary, ensure smooth movement or replace	
Compressor system continually discharges, low delivery quantity	Solenoid valve defective	Replace solenoid valve	
	Break in electric supply line to solenoid valve	Eliminate break	
No or insufficient feed quantity	Intake filter soiled	Replace filter Insert	
	Oil shortage	Check oil level, top up if necessary	7.4
	Intake control valve jams or is incorrectly positioned	Check control valve and control valve flap, clean bearing and guides, check stroke, replace if necessary	
	Leaks in system	Check, seal	
Control valve does not open	Compressor system leaky	Check system and seal off if necessary	
	Solenoid valve/electrical system, bypass valve, piston gasket, and minimum pressure valve not functioning	Check and replace parts	
Control valve does not control (two-point/stepless)	Pressure switch in system is set incorrectly	Check setting, adjust and replace if necessary	
Oil escapes during stop	Sealing surfaces in control valve damaged, spring in control valve broken	Check and replace parts	
Compressor system does not discharge (discharge time 100 - 200 seconds, depending on separator size)	Solenoid valve/electrical system not functioning	Check and replace parts	

Fault	Possible cause	Remedy	See chapter
Control valve constantly discharges	Solenoid valve/electrical system not functioning	Check and replace parts	
Oil escapes during discharging (oil foam in air-oil separating element)	Oil type incorrect	Change oil	7.5
	Oil foam forms during stop	Check and replace discharge delay valve, with a different nozzle diameter if necessary	
	Oil level too high	Drain off oil	7.4
Abnormal noise during operation	Insufficient lubrication, loose parts, damage to drive, transmission, bearings, or shaft, etc.	Check, if necessary, replace parts or have them replaced	