



MEEA
MOBILE ENERGY AUSTRALIA
Specialists in vehicle mounted compressor & generator systems

SMARTPACK 35 PLUS

(SP35 PLUS)

Owners & Operators Manual

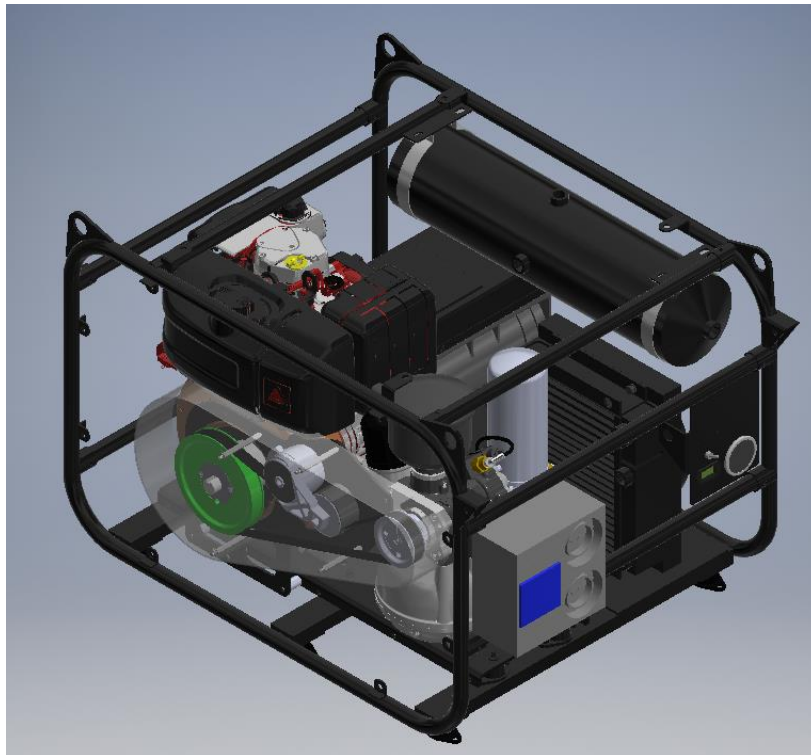

**30CFM Compact Air Compressor -
Generator**

**THIS PAGE IS LEFT BLANK
INTENTIONALLY.**

MEA Product Registration Form

**THIS FORM MUST BE COMPLETED AND
RETURNED WITHIN 30 DAYS OF INSTALLATION
OR
WARRANTY WILL BE VOID**

CUT HERE



MEA Product Warranty Registration Form

This form must be completed and returned to MEA at the time of Installation. Warranty will be void if this form is not received by MEA within 30 days of installation.

MEA Dealer Information

Company Name: _____

City: _____ State: _____ Country : _____

MEA Installer Information

Company Name: _____

City: _____ State: _____ Country : _____

Installation Date: ____ / ____ / ____
 Day Month Year

Owner Information

Company Name: _____

Address: _____

City: _____ State: _____ Country : _____

Postcode: _____ Phone #: _____

Product Information

MEA Serial Number: _____

Model Number: _____

Document No 7220-D0001

Table of Contents

PRODUCT SAFETY	2
INTRODUCTION	3
SPECIFICATIONS	4
OPERATING PROCEDURE	5
INSTALLATION	ERROR! BOOKMARK NOT DEFINED.
SCHEDULE MAINTENANCE	10
SPARE PARTS AND SERVICE KITS	11
TROUBLESHOOTING	13
DRAWINGS & ILLUSTRATIONS	14
WARRANTY	18
MOBILE ENERGY AUSTRALIA - CONTACTS	20

Both the MEA Product Warranty Registration form (located at the FRONT of this Manual) and the Kohler Engine Warranty Registration form (located at the back of this manual) are to be returned to MEA.

FAILURE TO RETURN EITHER FORM MAY RESULT IN THE PRODUCT WARRANTY BEING VOID.

PRODUCT SAFETY

(COMPRESSOR / COMPRESSED AIR)

MEA DISCLAIMS ANY AND ALL LIABILITIES FOR DAMAGE OR LOSS DUE TO PERSONAL INJURIES, INCLUDING DEATH, AND/OR PROPERTY DAMAGE INCLUDING CONSEQUENTIAL DAMAGES ARISING OUT OF ANY MEA SYSTEM NOT USED IN ACCORDANCE WITH THE OPERATOR INSTRUCTIONS.

ALL UNITS ARE SHIPPED WITH A DETAILED OPERATOR MANUAL. THIS MANUAL CONTAINS VITAL INFORMATION FOR THE SAFE USE AND EFFICIENT OPERATION OF THIS UNIT. CAREFULLY READ THE OPERATORS MANUAL BEFORE STARTING THE UNIT. FAILURE TO ADHERE TO THE INSTRUCTIONS COULD RESULT IN SERIOUS BODILY INJURY OR PROPERTY DAMAGE.

Care is required when working with an air compressor or compressed air. Compressed air is one of the many ways energy can be stored. Releasing the stored energy in an uncontrolled manner can result in catastrophic consequences. Death and permanent disability are all possibilities that can occur. The following are suggested as minimum precautions to be used when operating the SMAC Air Compressor. It is important that each work site engages in a risk analysis of that site and produces procedures to minimise injury to their employees. Health and Safety Regulations today require that this is a compulsory process to be carried out on each site. These, with site specific designed safety precautions will help to reduce accidents, personal injury, and loss of life. It is the responsibility of the employer to ensure that the work site is safe for the employees.

SAFETY WHEN OPERATING AN AIR COMPRESSOR

- Do not bypass or disable the oil temperature sensor.
- Do not expose the tank or compressor to extreme heat.
- Do not perform any service or repairs until the system has been completely relieved of air pressure.
- Maintenance and repairs on the system should only be done by qualified personnel.
- Do not operate the compressor while driving.
- Do not tamper with the pressure relief valve.
- Run the system at idle speed and under no load conditions for 2 to 3 minutes before turning the system off to allow system cooling and lubrication to occur.
- Follow safe work practices, wear the appropriate safety equipment when operating air-powered equipment, particularly eye and hearing protection.
- Avoid contact with rotating components, ensure all safety guards are in place.
- Avoid all contact with pressurized air. If it penetrates, your skin, it can enter your blood stream and cause death.
- To prevent compressor explosion or fire, make sure that the air entering the compressor is free of flammable vapors.
- Vaporized oil propelled by high pressure is an explosive mixture.
- Do not breathe the compressor air, vaporized oil is a respiratory hazard.
- Stay clear of all moving parts when the system is operating.

INTRODUCTION

The MEA (SP30PG) SmartPack 30 – Petrol with Generator utilizes a single cylinder petrol engine to deliver power via a synchronous belt to a self-contained twin screw compressor. The engine is also directly coupled to a 3.5kVA generator and packaged in the smallest frame possible to ensure the SP30PG can be used on the back of a work utility vehicle as easily as it can be used in a garage, workshop, or property. This manual has important information on the system and how it is to be operated. It also contains information on how it should be installed if it is to be vehicle mounted.

This document also contains all the information on the schedule for servicing and maintenance. Please note as this is a compressor system with pressures that are dangerously high to humans, all service and maintenance that involves any part of the compressed air system must be carried out by a trained professional. Failure to do so may result in permanent injury or death and MEA cannot, under any circumstance, be held responsible if the compressed air system has been tampered with by an untrained person.

SPECIFICATIONS

Compressor Type:	Oil injected rotary screw compressor
Drive System:	Petrol or Diesel powered via synchronous drive belt
Control:	Pneumatic
Maximum Air Delivery	30 CFM @ 150 psi
Pressure Regulation:	Mechanical inlet control valve modulates flow in response to demand
Inlet Valve Regulation	Pneumatic
Generator	2 Pole Single Phase 3.5kVA
Drive System:	Petrol powered via direct couple J609b
Engine Control System:	Pneumatic speed control, engine and compressor high temperature and pressure engine shutdown system
Safety Features	Relief valve in compressor sump Temperature safety sensor in the compressor
Lubrication:	All replacement compressor oils must be approved by MEA prior to use. Warranty will be nullified if oil has not been approved. MEA certified and approved synthetic compressor oil Part Number 10019 – P0002 Quantity of Compressor Oil Required – 3.5 Litres
Filters	Paper-type replaceable air filters Spin-on type compressor oil filter element Coalescing filter element

OPERATING PROCEDURE

CHECKS REQUIRED PRIOR TO STARTING EACH DAY

1. Check the oil level in the engine.
2. Check the oil level in the compressor.
3. Check all hoses are secured and not damaged. Replace all damaged hoses before starting.
4. Check all electrical cables are secure. Secure all cables that are not tied down.
5. Check the air inlet and air filter on the engine are clear.

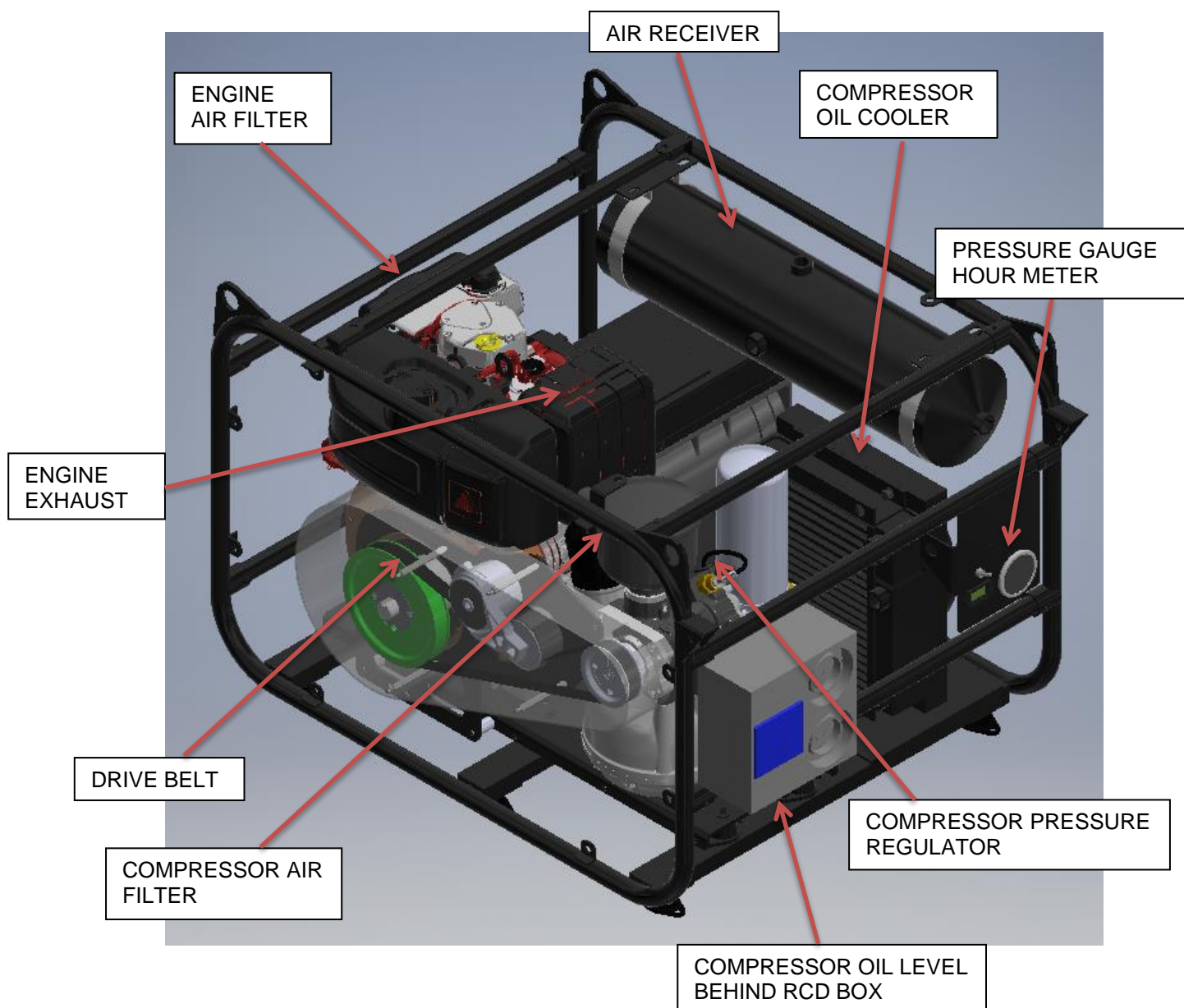

STARTING / STOPPING UNIT

STARTING THE PETROL ENGINE

1. Check the COMPRESSOR SWITCH is set to the OFF position.
2. If the engine is cold, ensure the choke is applied (under the air filter).
3. Ensure that the fuel tap is on (under the air filter).
4. Turn the key to the right until the engine has started and then release the key.
5. Slowly release the choke ensuring the engine remains operational.
6. Allow the engine to run at no load for 2-3 minutes. This will allow the engine to warm up and lubrication system to be fully operational before the load is applied.
7. If the engine does not start, repeat the process described in 2, 3 and 4. The maximum number of attempts should be limited to 5 and after this; the operator should seek assistance from a mechanic.

STARTING THE COMPRESSOR

1. Set the COMPRESSOR SWITCH to the ON position.
2. Listen for air escaping from the pressurized air system. Ensure all airline taps are closed to reach pressure.
3. If the escaping air is from a broken pipe or connection, turn the COMPRESSOR SWITCH to the OFF position. Stop the engine. Advise your maintenance department that you require their assistance.
4. The engine will reduce its RPM when the compressor reaches the preset pressure. The compressor is now ready to be used.

STOPPING THE COMPRESSOR UNIT

1. Disengage the compressor by moving the compressor engage switch to the “Compressor Off” position.
2. The compressor will shut down and bleed off pressure. The engine will come down to idle speed.
3. It is good practice to allow the engine to run under no load for 2-3 minutes.
4. Turn the engine off by turning the ignition key to the off position. If you hear a slight “hissing” noise this is normal, the compressor is bleeding off excess pressure out of the system.
5. Please note that to ensure no shock loading is placed on the engine and transmission belt, the compressor will not re-engage until the internal pressure in the compressor and separator tank reaches zero. The storage tank will still hold pressure.

The compressor is a rotary screw type driven by a petrol engine. Compression occurs when inlet air (at normal atmospheric pressure) enters a chamber where it is trapped between the rotating rotor lobes. A lubricated pitch line provides sealing. As the lobes mesh, they reduce the volume of the air, compressing it to the desired pressure.

The system has a two-stage air/oil separator. The first separation stage consists of baffles, which perform mechanical separation. The second stage uses a special separation element, which delivers dry air to the outlet. The second stage is a spin-on type coalescing filter.

Pressure regulation is achieved by adjusting the differential pressure regulator valve mounted on the tank. (Gold valve). The system pressure is pre-set at a range of 100psi to 130psi. Below 100 the engine will speed up to running specifications and charge the tank, above 130 the engine will slow down to idle, and the compressor will enter standby.

The compressor air intake is protected by a paper-type replaceable air filter, and a spin-on type oil filter for the oil side and a coalescing filter for final oil removal from the air.

Safety features included in the compressor are:

- 150 PSI relief valve in separation manifold.
- Blow-down valve to discharge system pressure on shutdown.
- Over temperature safety sensor in the compressor oil.
- Over pressure control mounted at the minimum pressure valve.
- **Do not disable or bypass the over-temperature shutdown circuits. Failure of the shutdown system could result in equipment damage, injury, or death.**

A liquid-to-liquid oil cooler maintains operating temperatures in an optimal performance range. This helps to increase system durability.

Mounting the Compressor Unit to Vehicle

The starting point for the installation is a quick overview of the requirements. Some of these points will be dealt with in more detail further on in this text. Things that should be considered now are as follows.

1. The unit should be installed in an open area.
2. The unit will need to be properly secured to the vehicle by means of bolts and nuts.
3. It should be possible that the sight level glass for oil level can be checked easily.
4. It should be possible to service the unit easily without having to remove and reposition the unit.
5. The unit should be protected from excessive exposure to the elements and possible incidental damage from other operations.
6. The unit should be installed in an area away from heat sources such as engines, exhaust systems or other components that generate heat.
7. The unit should not be installed in a location where it will be exposed to high contamination levels or combustible gases.
8. The engine exhaust should be considered when installing to ensure that other components on the vehicle do not get heat blasted.
9. The unit should be mounted in a way, so the compressor and engine air intakes are not exposed to a heat sources.
10. If mounting the unit in an enclosed space, direct the engine exhaust outside the enclosure.

Considering Ventilation

It is not possible to make absolute recommendations regarding ventilation because of the widely differing circumstances that are possible. Duty cycle, ambient temperature and enclosure shape are some of the important variables. Ideal ventilation will provide good airflow through the unit with no restrictions. There are two ways in which the SP30 compressor can be mounted.

Top or Deck Mounting

This is the preferred mounting location. Placing the unit in an area where there are no restrictions on the intake of fresh air and exhausting of hot air and exhaust gases, provides the best cooling and ensures reliability and life for the compressor / diesel engine driven unit.

Enclosed Mounting

It is important that discussion occurs between the manufacturer and the person installing the unit when it is to be placed in an enclosed area. Ventilation is one of the most important things to consider when looking at the installation of a compressor/diesel engine's driven unit in an enclosed area. It is important that the air intake to the compressor and the engine exhaust are located outside of the enclosed space. The unit generates a considerable amount of heat when running. Proper ventilation is vital for ideal operation and to avoid damage to the components. Ensure there is a minimum of 10" (250 mm) clearance between the exhaust and any other components mounted on the vehicle. If this is not possible and was not discussed prior to purchase, please contact MEA to purchase an exhaust deflector. It is strongly recommended that the installation is tested if the unit is installed in an area considered to be enclosed mounting. The following is a method suggested for testing.

1. It is best to test the installation at the hottest expected ambient temperature.
2. Setup and run the system at 120 PSI. This can be done by installing a ball valve on the air outlet pipe and adjusting the opening of the valve so that the compressor is running continuously at 120 PSI.
3. Record the engine, compressor, and current ambient temperature for future reference.
4. Run the system at full load for at least one hour or until the temperatures stabilize. Temperature stabilizing means there is no rise in temperature for 15 minutes when the compressor is running at the rated load.
5. Record the engine and compressor temperatures every 10 minutes.
6. If the system over-heats - the ventilation is not sufficient. Review the installation, make changes as needed, and repeat the test.

Completing the Installation - Before the First Startup

Make sure that the following have been completed before operating the MEA SmartPack30 Petrol Engine Driven Compressor Unit:

1. Check the compressor oil level; Note that the oil is very clear, and it is difficult to see the level.
2. Check the engine oil level.
3. Check fuel level.
4. Do a final inspection to make sure that all fasteners and connections are tight.
5. Check that all hoses and wiring are secure and protected.
6. Connect the battery cables to the terminals; always connect the Negative terminal first.

Check Operation – Setup & Performance Testing of Diesel Driven Compressor.

1. The compressor is dispatched from the factory with the pressure preset to the customer specification. Should the customer want to alter this setting, the instruction on how to do this can be found in the compressor manual.
2. Install the ball valve on the outlet of the hose from the compressor. Set the ball valve to the closed position.
3. Refer to Page 6 of this manual for the method to be used to start the compressor.
4. After starting, running, and charging the tank, the air pressure will be found to be at the pressure specified by the customer and the engine will be at the lower speed (idle speed). The Unit has been adjusted by the factory to the customer specification. If the pressure is not at the specified pressure, refer to MEA before attempting any adjustments.
5. Listen for leaks in the air line. You should hear a hissing sound if there are any leaks. Rectify any leaks you may find.
6. Keep the system running at the preset pressure until the compressor is up to operating temperature (fan switches on).
7. Using the ball valve located on the outlet of the compressor, slowly open the ball valve, and watch the pressure drop. The pressure will drop up to the point that the pressure is 30 PSI below the running pressure. The engine will speed up to the maximum preset RPM.
8. Keep the opening of the ball valve at the setting described in (7) above for about 5 minutes. The engine should continue to run at the maximum preset RPM.
9. Slowly close the ball valve and watch the pressure while closing. The engine will drop to the lower speed when the pressure reaches running pressure.
10. Your compressor is working correctly if it is operating as per this description.

SCHEDULE MAINTENANCE

This section is dedicated to the maintenance schedules as outlined by the engine and compressor manufacturer under standard operating conditions. If the conditions are severe, steps need to be taken for the affected areas to be maintained at shorter intervals
Daily inspection should happen before each startup.

SERVICE INTERVAL	COMPRESSOR
Periodically During Operation	Observe all gauge readings. Note any change from the normal reading and determine the cause. Have the necessary repairs made? (Note: "Normal" is the usual gauge reading when operating at similar conditions on a day-to-day basis.)
Periodically as required	Inspect and replace spin-on coalescing element if necessary.
	Inspect and clean oil cooler fins.
Every 10 Hours or Daily	Check for oil and/or air leaks.
	Check the compressor oil level.
	Check air filter/s and connecting hose and clamps
Every 25 Hours or Monthly	Check for oil and air system, including hoses, for leaks
	Drain water from than and check Compressor oil level
After first 50 hours of operation	Check system for oil and/or air leaks
	Check engine/compressor mounts fastener torque.
	Check belt and pulleys for signs of wear - note that belt normally gives off blue particles until it runs in
Every 100 Hours	Check engine/compressor mounts fastener torque.
	Check compressor oil level
	Check system for oil and/or air leaks
	Clean air cleaner element
	Check engine/compressor/generator mounts for excessive wear and fastener torque.
Every 400 Hours of operation or 9 months	Change compressor oil 3L
	Change compressor oil filter
	Change compressor air filter
	Check belt and pulleys for signs of wear
	Check engine/compressor mounts fastener torque.
800 Hours / 18 months	Change compressor oil filter
	Change compressor coalescing filter
	Change compressor air filter

SPARE PARTS AND SERVICE KITS

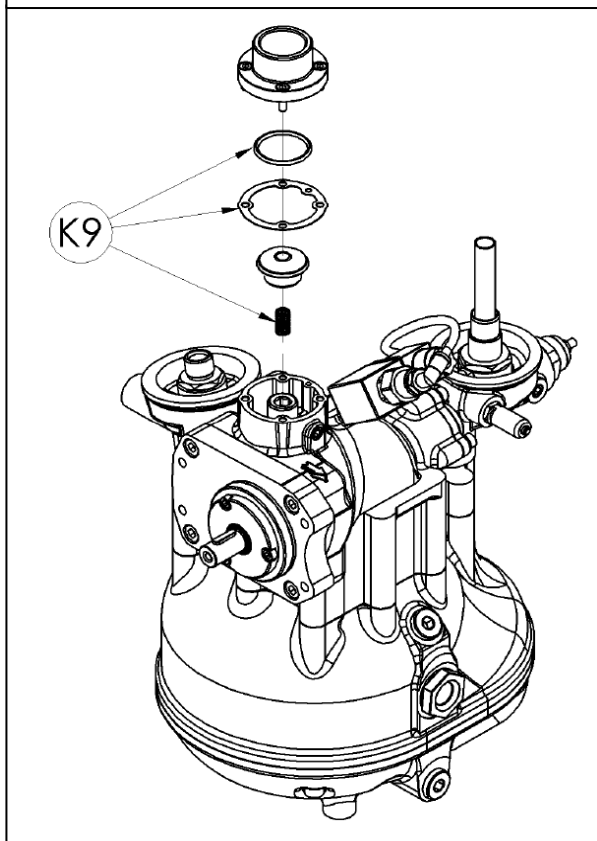
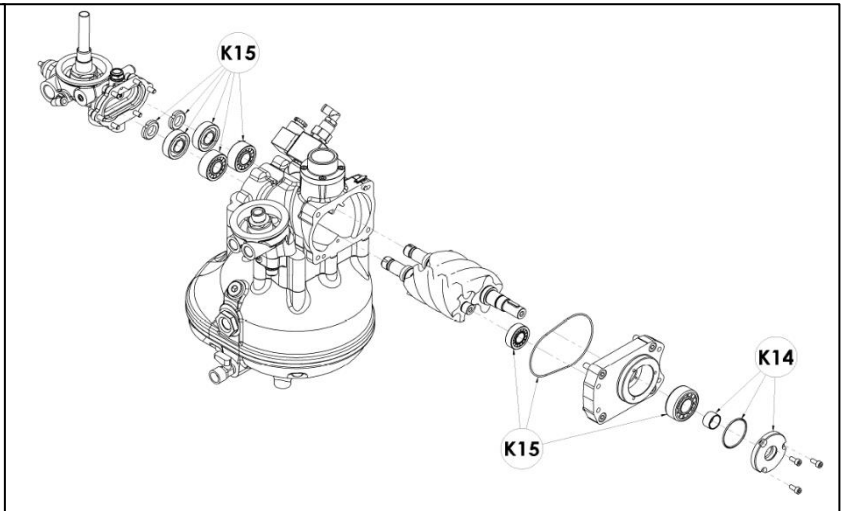
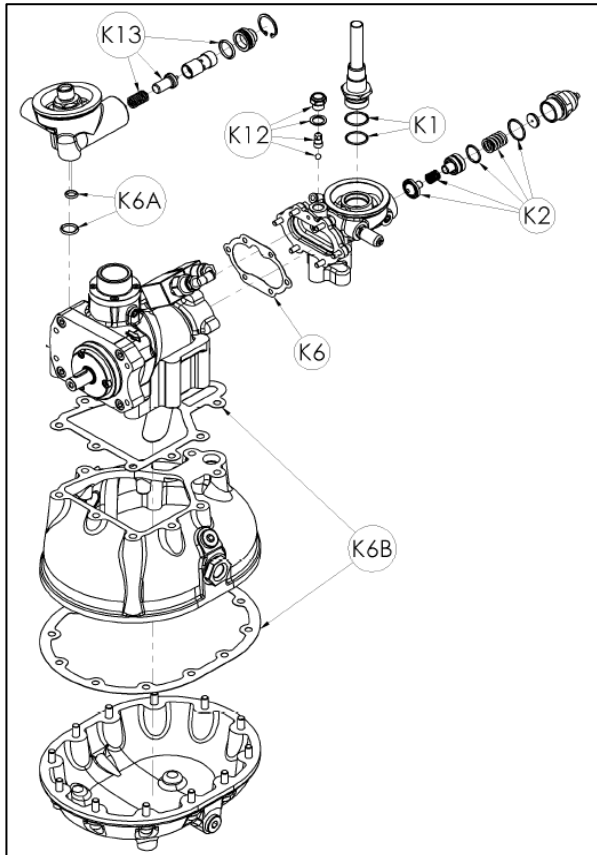

MEA PART NUMBERS	DESCRIPTION	PACK SMART	PACK SMART	PACK SMART	WORKING HOURS
		V61B 55°	V61B 71°	V61B 83°	
K1	270.0590 M22-M24 SEPARATOR NIPPLES SPARE PARTS KIT	•	•	•	Corrective maintenance
K2	220.0010 V.M.P. G10 (1/2-3/4) SPARE PARTS KIT	•	•	•	after 8000 hours
K6	725.0070 VDM SEAL PACK SMART V61 SPARE PARTS KIT	•	•	•	Corrective maintenance
K6A	725.0072 VTFT SEAL PACK SMART V61 SPARE PARTS KIT	•	•	•	Corrective maintenance
K6B	725.0071 TANK SEAL PACK SMART V61 SPARE PARTS KIT	•	•	•	Corrective maintenance
K9	600.5090 RH30E-nr COMPLETE SPARE PARTS KIT	•	•	•	after 8000 hours
K12	725.0090 INTERNAL OIL RECOVERY VIEWER	•	•	•	Corrective maintenance
	725.0050 THERMOSTATIC VALVE SPARE PARTS KIT 55°	•	•	•	
	725.0051 THERMOSTATIC VALVE SPARE PARTS KIT 71°	•	•	•	after 8000 hours
K13	725.0052 THERMOSTATIC VALVE SPARE PARTS KIT 83°	•	•	•	
	900.5244 V61 AIR-END OIL SPLASHGUARD SPARE PARTS KIT	•	•	•	after 8000 hours
K14	900.5248 V61 AIR-END BEARINGS SPARE PARTS KIT	•	•	•	after 20000 hours

SMARTPACK 35D SERVICE KITS AND PART NUMBERS

200 Hour - 7219-KB0001		
Part Number	Description	Quantity
10019-K0007	OIL 5 LITRE CONTAINER DIESEL	1
10021-P0006	DECAL OIL MEA OIL	1
10008-P0126	FILTER OIL ENGINE KOHLER	1
10008-P0128	FILTER AIR ENGINE KOHLER	1
7201-P0075	DECAL NEXT SERVICE DUE	1
400 Hour - 7219-KB0002		
Part Number	Description	Quantity
10019-K0007	OIL 5 LITRE CONTAINER DIESEL	1
10021-P0006	DECAL OIL MEA OIL	1
10008-P0126	FILTER OIL ENGINE KOHLER	1
10008-P0128	FILTER AIR ENGINE KOHLER	1
7201-P0075	DECAL NEXT SERVICE DUE	1
10019-K0005	OIL 5 LITRE CONTAINER COMPRESSOR	1
10001-P0076	FUEL FILTER INLINE	1
10008-P0041	FILTER OIL COMPRESSOR	1
800 Hour - 7219-KB0003		
Part Number	Description	Quantity
10019-K0007	OIL 5 LITRE CONTAINER DIESEL	1
10021-P0006	DECAL OIL MEA OIL	1
10008-P0126	FILTER OIL ENGINE KOHLER	1
10008-P0128	FILTER AIR ENGINE KOHLER	1
7201-P0075	DECAL NEXT SERVICE DUE	1
10019-K0005	OIL 5 LITRE CONTAINER COMPRESSOR	1
10001-P0076	FUEL FILTER INLINE	1
10008-P0041	FILTER OIL COMPRESSOR	1
10008-P0045	FILTER COALESCING	1
10008-P0111	FILTER AIR COMPRESSOR	1

IMPORTANT: PLEASE CONTACT MOBILE ENERGY AUSTRALIA FOR MORE INFORMATION IF YOU HAVE ANY QUESTIONS REGARDING THE SETUP AND OPERATION OF OUR RANGE OF PRODUCTS.

Troubleshooting

Engine

Problem	Possible Cause							
	No Fuel	Improper Fuel	Dirt In Fuel Line	Dirty Debris Screen	Incorrect Oil Level	Engine Overloaded	Dirty Air Cleaner	Faulty Spark Plug
Will Not Start	•	•	•		•	•	•	•
Hard Starting		•	•		•	•	•	•
Stops Suddenly	•		•	•	•	•	•	•
Lacks Power		•	•	•	•	•	•	•
Operates Erratically		•	•	•		•	•	•
Knocks or Pings		•		•		•		•
Skips or Misfires		•	•	•			•	•
Backfires		•	•			•	•	•
Overheats		•	•	•	•	•	•	
High Fuel Consumption						•	•	•

Compressor

SYMPTOMS	PROBABLE CAUSE	CORRECTIVE ACTION
The compressor does not load.	1-The intake valve remains closed.	1-Check the valve. If necessary, replace the damaged parts with K9 spare parts kit.
	2-The solenoid valve does not work accurately	2-Check the solenoid valve. If necessary, replace it.
	3-Losses on the pressure line.	3-Check pipes and cables. If necessary, replace them.
During idling phase, the compressor does not discharge pressure from separator tank	1-The solenoid valve does not work accurately.	1-Check the solenoid valve. If necessary, replace it.
	2-The calibrated nozzle is clogged.	2-Remove the calibrated nozzle. Clean or replace it.
Compressor capacity or pressure lower than usual standard.	1-The air filter is clogged.	1-Remove the air filter. Clean or replace it.
	2-The intake valve does not open.	2-Check the valve. If necessary, replace the damaged parts with K9 spare parts kit.
	3-Air loss from safety valve.	3-Replace the valve.
Compressor keeps on loading over working pressure: safety valve opens	1-The solenoid valve does not work accurately.	1-Check the solenoid valve. If necessary, replace it.
	2-Clogged separator filter.	2-Replace the separator filter.
Compressor overheating.	1-Insufficient cooling.	1-Check the cooling system. Check coolant level on tank.
	2-Dirty oil	2-Replace it with new oil.
	3-Oil level is too low.	3-Check coolant level on tank and if necessary, add oil .
	4-Clogged-up cooler or pipe connection	4-Clean cooler and pipes.
	5-The thermostatic valve does not work correctly.	5-Check the thermostatic valve. If necessary, replace the damaged parts with K3 spare parts kit.
	6-Clogged oil filter	6-Replace the oil filter.
During unloading phase, pressure increases up to safety valve opening	1-The intake valve remains open.	1-Check the valve. If necessary, replace the damaged parts with K9 spare parts kit.
	2-The calibrated nozzle is clogged.	2-Remove the calibrated nozzle. Clean or replace it.
Oil leakage from intake valve only when the machine is switched off: oil soaked-up air filter	1-The intake valve does not work properly (does not close)	1-Check the valve. If necessary, replace the damaged parts with K9 spare parts kit.
	2-The no-return valve of intake valve does not work correctly.	2-Check it and clean it.
Oil soaked-up air filter during unloading phase	1-Too high level of oil in the tank	1-Check oil level on separator tank (see the chapter 6).
	2- Clogged separator filter	2- Replace the separator filter.
	3-The recovery oil viewer is dirty or does not work appropriately.	3 -Clean it or if necessary, replace the damaged parts with the K11 spare parts kit. If separator filter is clogged up, replace it.
The compressor remains under loading phase.	1-The intake valve does not work properly (does not close)	1-Check the valve. If necessary, replace the damaged parts with K9 spare parts kit.

DRAWINGS & ILLUSTRATIONS

Engine Components

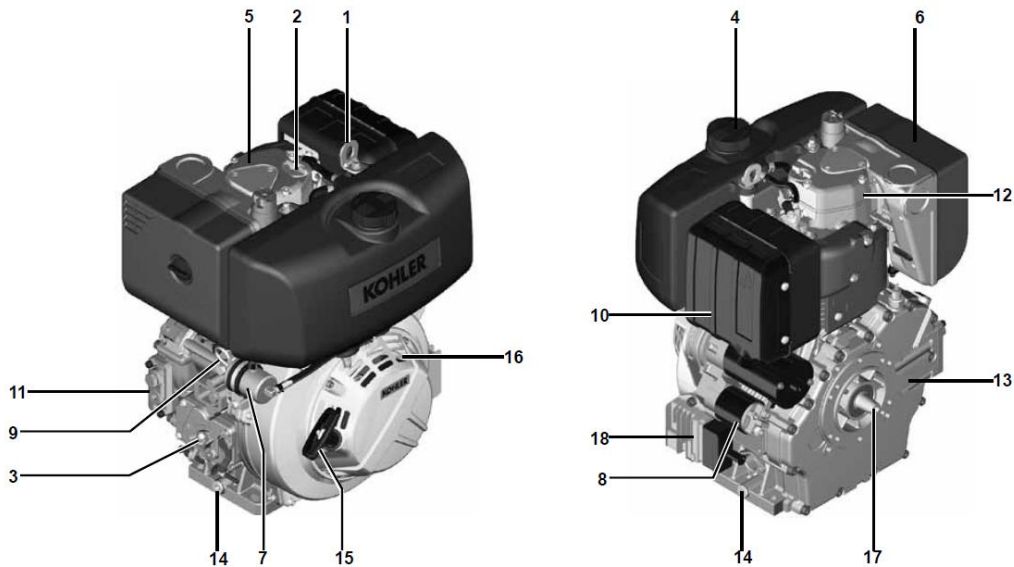

1	Lifting point on the engine
2	Oil refilling hole
3	Throttle lever
4	Fuel inlet
5	Rocker arm cover
6	Air suction intake
7	Fuel filter
8	Starter motor
9	Oil dipstick
10	Exhaust muffler
11	Internal oil filter
12	Cylinder head
13	Crankcase
14	Engine oil drain plug
15	Recoil starter
16	Engine cooling air intake
17	PTO on crankshaft
18	Voltage regulator

Pneumatic Circuit

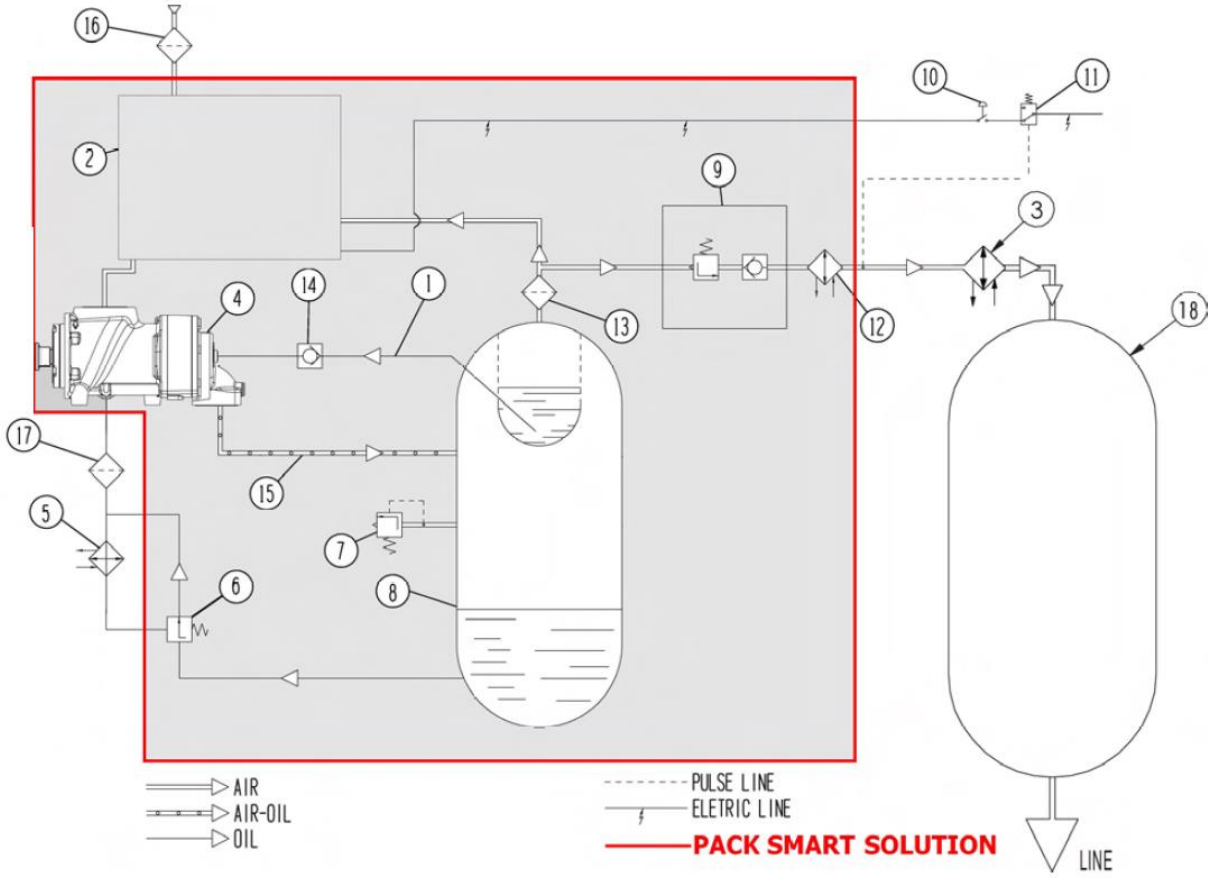

1. Oil return from separator
2. Intake valves
3. External after cooler
4. Screw Air-End V60
5. Oil cooler
6. Thermostatic valve
7. Safety valve
8. Air/Oil Separator tank
9. Minimum pressure valve
10. Switch to load/unload
11. Pressure switch controller
12. Internal After Cooler
13. Coalescing Filter
14. Oil level gauge
15. Air/Oil Line
16. Air inlet filter
17. Oil Filter

Wiring Diagram

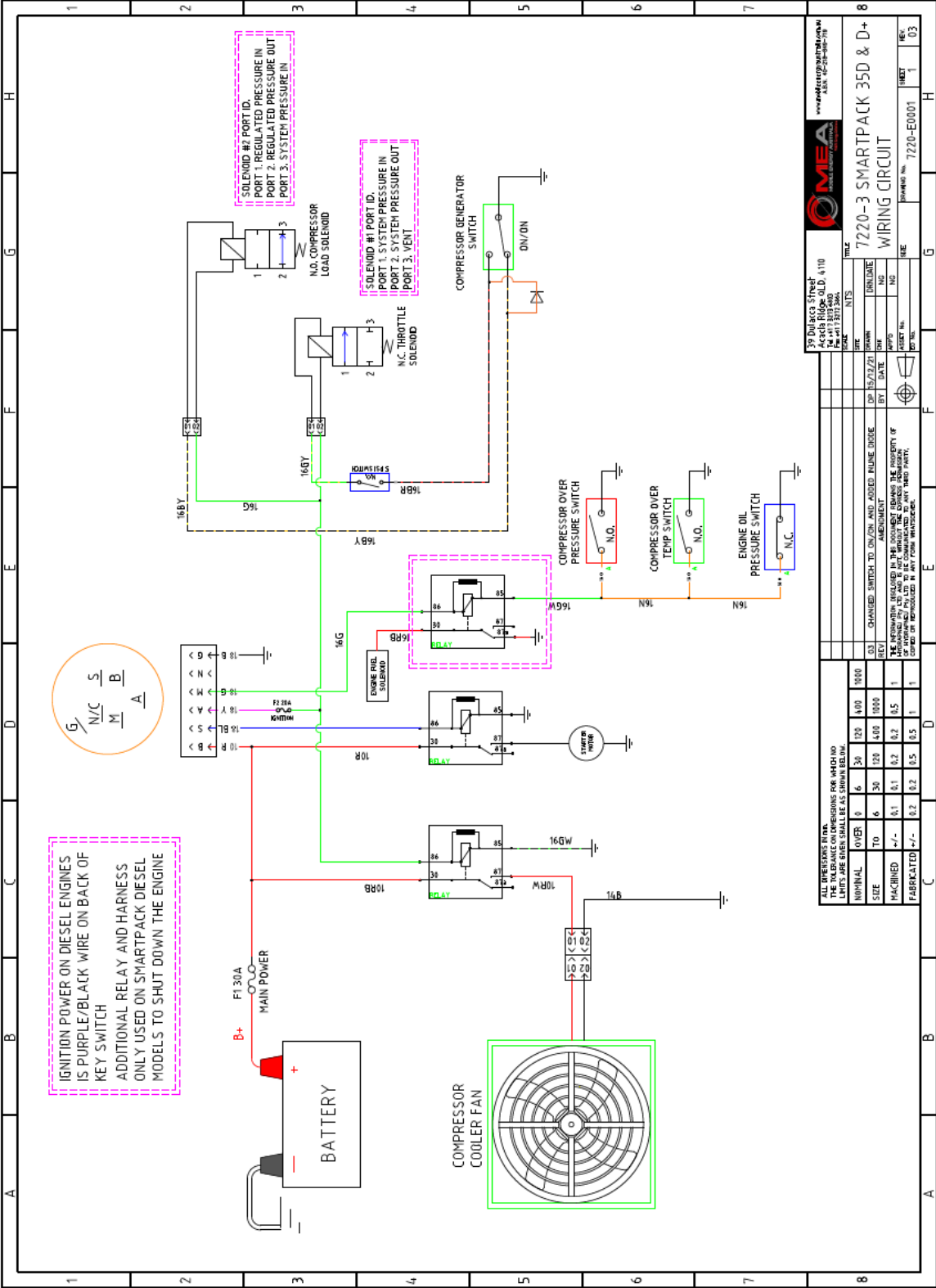

39 Dulacca Street
Acacia Ridge QLD 4110
Tel: +61 7 3273 6800
www.mobileenergyaustralia.com.au

7220-3 SMARTPACK 35D & D+
WIRING CIRCUIT

DATE	15/12/21	BY	DP
REV	01	CHANGED SWITCH TO ON/OFF AND ADDED INLINE DIODE	
DATE	15/12/21	BY	DP
REV	01	ADJUSTMENT	

THE INFORMATION CONTAINED IN THIS DOCUMENT IS THE PROPERTY OF MOBILE ENERGY AUSTRALIA PTY LTD. IT IS LOANED TO YOU BY THIS COMPANY AND IS NOT TO BE REPRODUCED OR TRANSMITTED IN ANY FORM OR BY ANY MEANS, ELECTRONIC OR MECHANICAL, INCLUDING PHOTOCOPYING, RECORDING, OR BY ANY INFORMATION STORAGE AND RETRIEVAL SYSTEM.

NOMINAL	OVER	0	6	36	125	400	1000
SIZE	TO	6	26	128	400	1000	
MACHINED	+/-	0.1	0.1	0.2	0.2	0.5	1
FABRICATED	+/-	0.2	0.2	0.5	0.5	1	1

Generator

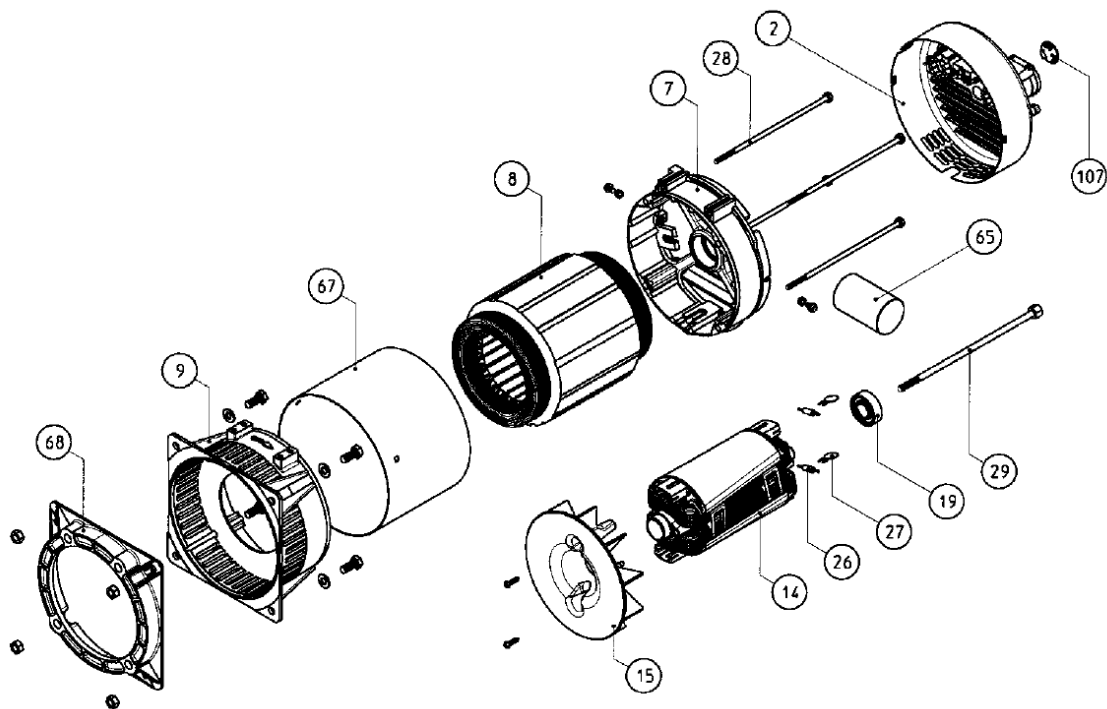

N°	NAME
2	TERMINAL BOX LID
7	NON DRIVE END BRACKET
8	STATOR
9	DRIVE END BRACKET
14	ROTOR INDUCTOR
15	FAN
19	REAR BEARING 6203-2ZC3
26	DIODE
27	VARISTOR
28	COVER STAY BOLT
29	SECURING STUD
65	CAPACITOR
67	LOCKING BAND
68	INTERCHANGEABLE FLANGE
69	MAGNETOTHERMIC
103	SINGLE-PHASE SOCKET
107	TERMINAL BOX PLUG

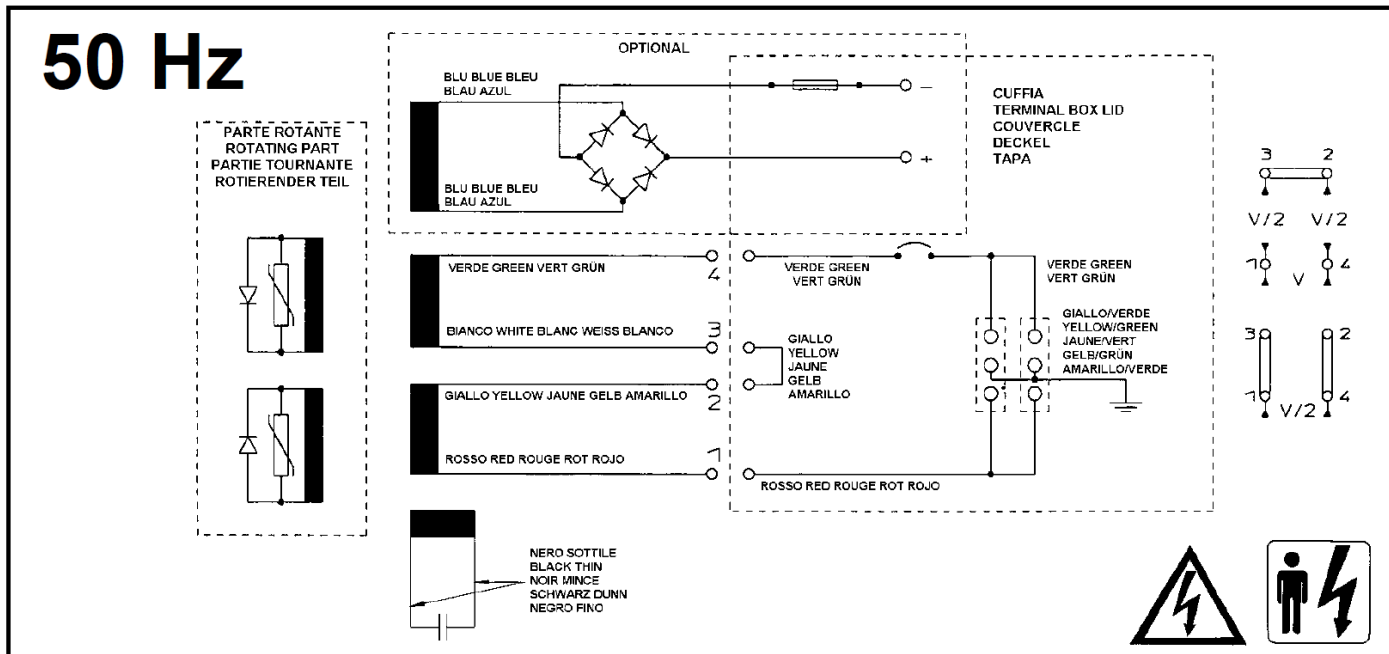

WARRANTY

1. GENERAL PROVISIONS AND LIMITATIONS

- 1.1 Mobile Energy Australia (hereafter “MEA”) warrants to each original retail purchaser (hereafter “Buyer”) that such product(s) are, at the time of delivery to the buyer, free of manufacture ring defects in material and workmanship.

2. NO WARRANTY IS MADE WITH RESPECT TO

- 2.1 Any product(s) which in the judgment of MEA has been subject to negligence, accident, improper storage, improper installation, improper application, improper operation, or maintenance or has been repaired or altered by others without the written authority of MEA.
- 2.2 Components or accessories manufactured, warranted, and serviced by others.
- 2.3 Damages caused by the lack of normal maintenance, service, and repairs such as the replacement and service of filters and seals.
- 2.4 Damages caused by the lack of normal minimum action, such as adjustments and inspections, replacement of items, such as service filters, seals, and service kits.
- 2.5 Consequential damages caused by product(s) failure.
- 2.6 Any product(s) if other than MEA’s genuine components are used in the product(s).
- 2.7 Normal wear and tear of product(s).

3. WARRANTY PERIOD

- 3.1 The warranty period will commence upon installation of the product(s). The returned registration form marks the date of installation. If the registration form is not received, the warranty period will be deemed to commence 30 days from the date of shipment from MEA.
- 3.2 The Product(s) is warranted against manufacturer defects in materials and workmanship for a period of 12 months.
- 3.3 The compressor air end is warranted to be free from defects in material and workmanship for a period of two (2) years from the date of installation.
- 3.4 Components supplied under warranty shall be warranted for the remainder of the original warranty period.
- 3.5 MEA factory rebuilt components shall be warranted for a period of 6 months from date of shipment.

4. MEA OBLIGATIONS

- 4.1 The obligation of MEA is limited to repairing or replacing parts, during normal business hours, at an authorized service facility, any component, that in the judgment of MEA are defective.
- 4.2 The obligation of MEA is limited to replacement of faulty parts. No liability is accepted for any freight costs, consequential damages, injuries, or expenses directly or indirectly related to the Product(s) failure.

5. BUYER OBLIGATIONS

- 5.1 Buyer shall notify MEA of the alleged defect within 10 days of initial discovery and return the allegedly defective component(s) within 30 days of initial discovery.
- 5.2 The Buyer must prepay all costs associated with the warranty.
- 5.3 The Buyer must return components claimed under this warranty to a facility designated by MEA for evaluation, to establish a claim under this warranty.
- 5.4 Buyer shall maintain and service MEA Product(s) in accordance with the MEA Product(s) Owner's Manual.

6. WARRANTY REGISTRATION VALIDATION

- 6.1 A registration form is provided to the Buyer with the product(s). The form must be fully completed by the Buyer and returned to MEA upon completion of the installation of the product(s) to validate the warranty. No warranty claims will be processed unless MEA has received a fully completed warranty registration form.

7. DISCLAIMER AND WARRANTY SERVICE

- 7.1 Any labor costs claimed more than MEA's set rate and/or times are not provided by this warranty. If applicable, any labor costs more than MEA rate schedules caused by, but not limited to, location or inaccessibility of the equipment, travel time or labor provided by unauthorized service personnel are not provided by this warranty.
- 7.2 This warranty is in lieu of all other warranties or obligations expressed or implied. MEA expressly disclaims all implied warranties of merchantability or fitness for a particular purpose.
- 7.3 Warranty claims must be pre-authorized by MEA, and the components returned via prepaid freight using the designated "Returned Merchandise Authorization" number and form.

PLEASE NOTE:

Both the MEA Product Registration Form and the Kubota Engine Warranty Registration Form MUST be returned to MEA in the stamped, self-addressed envelope.

WARNING!!!

Failure to return PRODUCT WARRANTY REGISTRATION FORMS detailed above may result in the delayed processing of warranty claims.

MOBILE ENERGY AUSTRALIA - CONTACTS

Sales

Email: sales@mobileenergyaustralia.com.au

Office: 07 3273 6803

Spare Parts

Office: 07 3273 6803

Email: spareparts@mobileenergyaustralia.com.au

Service

Office: 07 3273 6803

Email: workshop@mobileenergyaustralia.com.au